

Air/Oil Intensified Cylinders

Air Powered Hydraulic Cylinders for Forming and Assembly

Clinching

Piercing

Riveting

Stamping

Bending

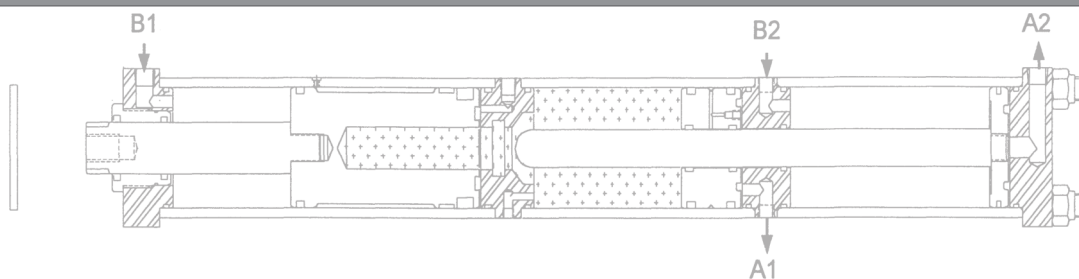

Eleven standard sizes available from 1 to 100 tons

Two standard design configurations available

Ideal for a wide variety of applications



www.btmcomp.com

810-364-4567

BTM COMPANY

BTM, since its founding in 1966, has been driven to offer innovative solutions at economical prices. Currently offering a variety of standard products for automation, BTM serves an array of industries including automotive, appliance, HVAC, and more. In addition to our standard products, BTM

also has the capability to design and build special machines ranging from simple press units to fully automated turn-key systems. Our modern machine shop also has the capability to handle the machining of a large variety of part sizes, shapes, materials, and complexity.

CONTACT BTM TO LEARN HOW OUR INNOVATIVE SOLUTIONS CAN REDUCE COSTS & IMPROVE YOUR PRODUCTIVITY!

A SIZEABLE ADVANTAGE

Our 125,000 square feet located in Marysville, Michigan is equipped with modern state of the art CNC machines which allow us to maintain control of quality and delivery. Our business has also been built on a quick response to service & support.

BTM strives to make the best products on the market, supplied on time and defect free.

As technology innovators, we are continuously thinking to improve products and processes.

Our manufacturing and machine building capabilities are of a world class status.

BTM STRIVES TO:

- Take an innovative approach to problem solving with emphasis on cost reduction
- Give attention to detail during project management
- Provide timely response to customer requests
- Accommodate running product design changes
- Make application of our time tested knowledge and experience
- Apply our knowledge of customer specifications

WWW.BTMCOMP.COM

BTM FACILITIES

The BTM headquarters consists of three buildings:

- 1 Manufacturing
- 2 Special Products Division
- 3 Standard Products

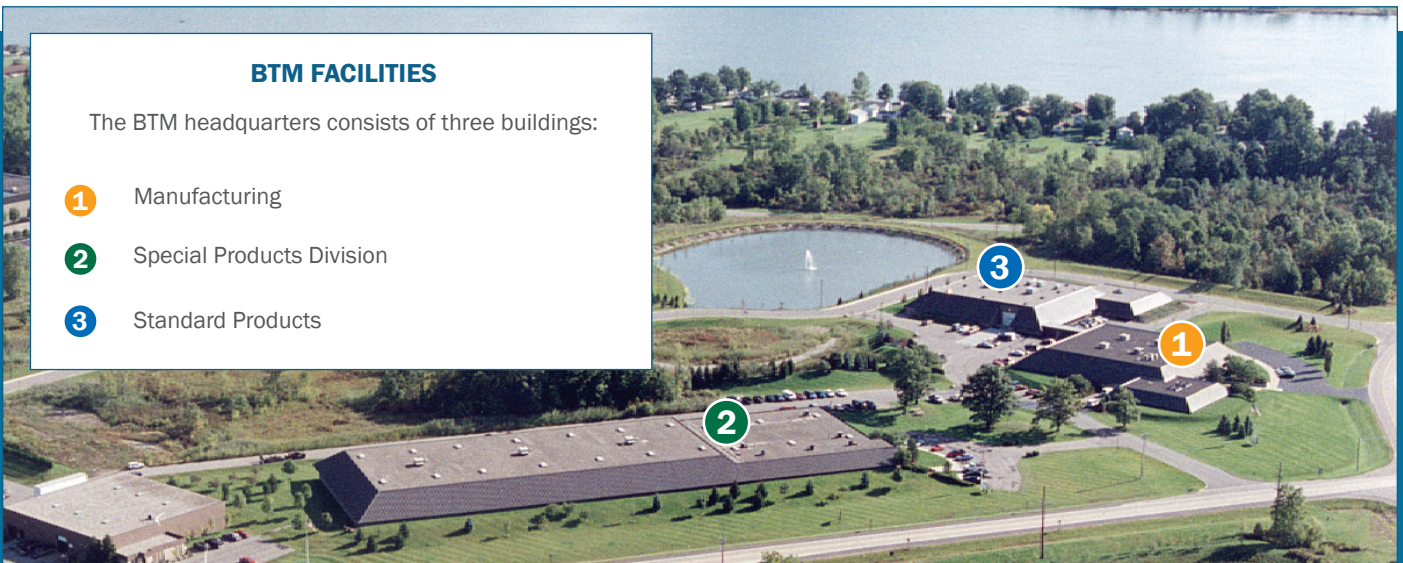



BTM'S AIR/OIL CYLINDERS

BTM Air over Oil Cylinders generate a pneumatic-hydraulic power stroke using only compressed air. The power stroke can be initiated by distance, time delay, or part contact (opposing force), based on the preference of the user.

Each cylinder is self-contained and constructed using a "modular sandwich design" joined together with either four or eight tie-rods, the number of which depends on the model.

BTM cylinders are designed to operate with compressed air ranging from 30 to 100 PSI (approximately 2 to 7 bar) maximum. The output forces in the power stroke range from 670 lb. to 142,900 lb, (1.5 kN to 1750 kN) depending on the model.

ADVANTAGES AND FEATURES

- Eliminates the need for hydraulic power units
- Clean, quiet, reliable operation
- Environmentally friendly
- Operation in any position or attitude
- Total air/oil separation in reservoir and working sections
- Heavy duty, all CNC machined construction
- Totally self-contained unit – no external reservoir required
- 3 Year warranty

NEED A SPECIAL SOLUTION? WE SPECIALIZE IN SPECIALS!

Special cylinders and equipment can be purchased from BTM ranging from simple presses/fixtures to fully automated turn-key solutions. We offer a range of applications and tooling including Tog-L-Loc and Lance-N-Loc fastener-less sheet metal joining systems. Additional applications include riv-loc fastening, piercing, swaging, stamping, shearing, and more. Contact one of our application engineers to learn more about how BTM can build a special solution to satisfy your unique production requirements!

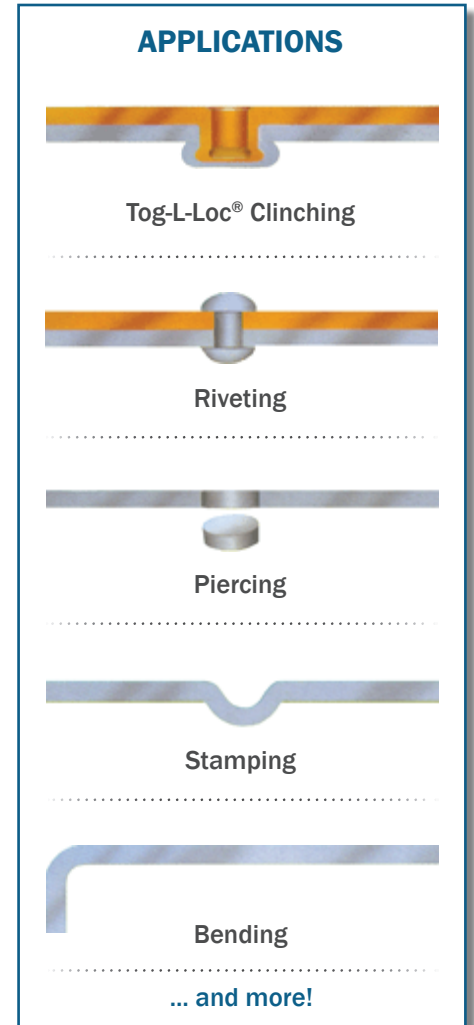

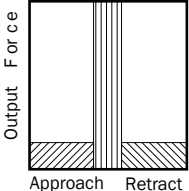
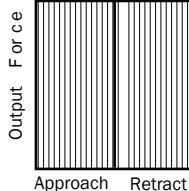
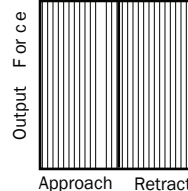
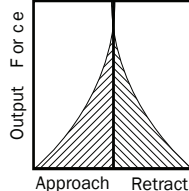
	BTM A/O Cylinders	Air Cylinder	Hydraulic System	Pneumatic Toggle
1 Investment	Low to moderate vs. other systems, low installation and electrical costs.	Low to moderate depending on force required. Limited force.	Moderate to high depending on force and speed required. Requires additional floor space, electrical, and installation costs.	Moderate to high, limited force range.
2 Operation	Linear power curve, user adjustable within size range. Soft contact with tooling prior to power stroke. Self-contained power source. Clean, quiet, compact.	Linear power curve, user adjustable within size range. Full contact force with tooling. Large size, large controls.	Linear power curve, noisy, can run hot without oil cooler. Full contact force with tooling without special circuit. Large floor space required on high force/high speed applications. Multiple components.	Parabolic force curve. Large size, mechanical linkage requires adjustment. Self-contained, clean. Large controls
3 Force Curve				
4 Energy	Very low per lb. of output force. Example: HPI-4 Series with a 4.00" stroke uses .081 SCFM per cycle vs. 1.23 SCFM for an equivalent air cylinder.	High air consumption per lb. of output force.	Electrical costs for system pump(s), motors, coolers, pre-heat elements.	High air consumption per lb. of output force.
5 Maintenance	*Minimal. Cylinder service consists of refilling internal oil reservoir. Only three moving parts.	Very low. May require air supply lubrication.	Very high. Oil and filter changes, oil disposal (hazardous), multiple related components	Moderate to high. Linkage wear may alter force position and output.
6 Setup and Use	Use of power stroke anywhere within stroke of cylinder. Two 4-way air valves and 30-100 PSI air supply required for operation. Soft contact force reduces noise, extends tooling life. Approach, retract, and power stroke speeds and forces fully user adjustable.	High impact forces. Force constant throughout stroke. One air valve and air supply required. Output force and speed user adjustable.	High impact forces without special circuit. Many components to troubleshoot. Multiple electrical and hydraulic lines. May run hot without cooler. Typical pump/motor displaces high dB noise. Requires drip pans to contain oil leakage.	Parabolic force curve requires adjustment of press, tooling, or part stackup to attain proper force. Damage to press/tooling may result from improper setup. Requires constant lubrication.
7 Disadvantages	Some units are longer in length than conventional air or hydraulic cylinders. Standard power stroke limited to 1.00" of travel. Custom power stroke distance available upon request.	Large size, high air consumption.	Many system components, high energy use, oil leakage, high maintenance.	Parabolic force curve, mechanical linkages.

*MTBF reports on file. Usable cylinder service life using a filtered and lubricated air supply is approximately 20 million cycles.

HOW BTM CYLINDERS WORK

The In-Line and Satellite cylinders require two (2) pneumatic 4-way directional control valves and a plant air supply for proper operation.

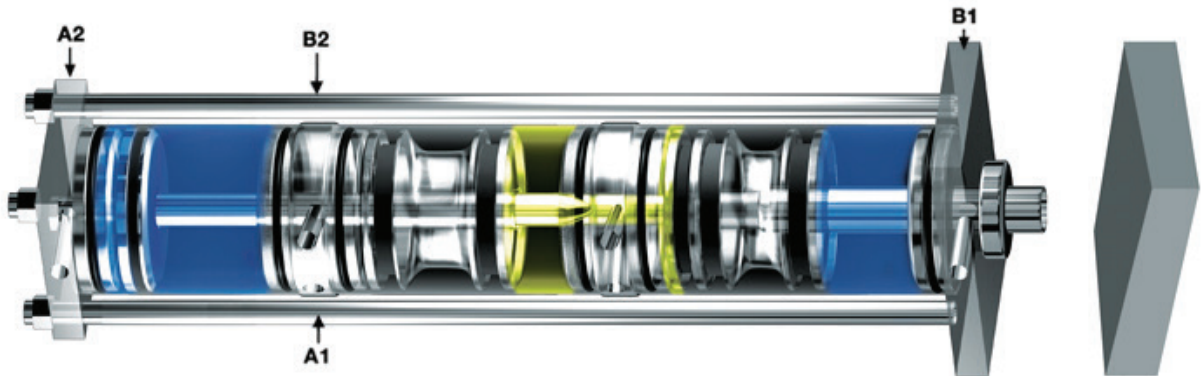

Figure 1. Cylinder Retracted

Air is directed to ports B1 and B2, fully retracting the reservoir, working, and high pressure pistons.

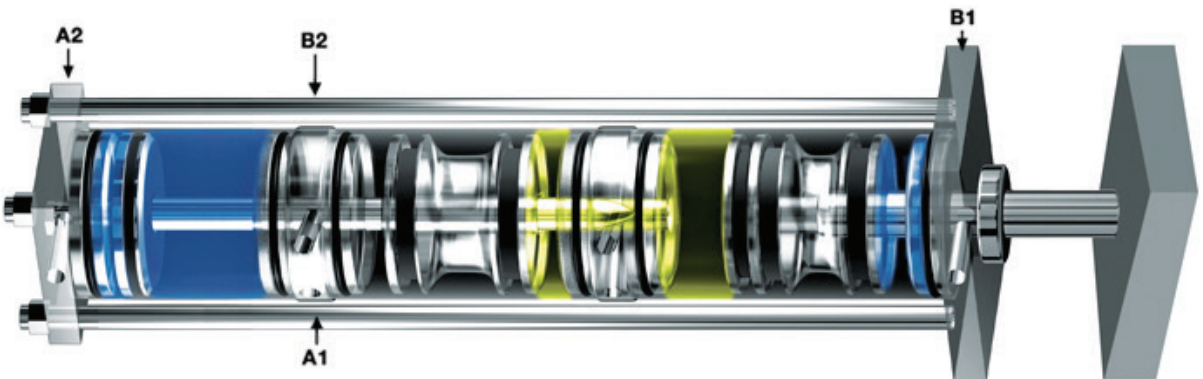

Figure 2. Approach Stroke

Regulated air is directed to port A1. The reservoir piston advances, displacing the reservoir oil through the valve block (yellow area) to the back of the working piston, advancing the cylinder rod (at low force) until meeting resistance (work surface).

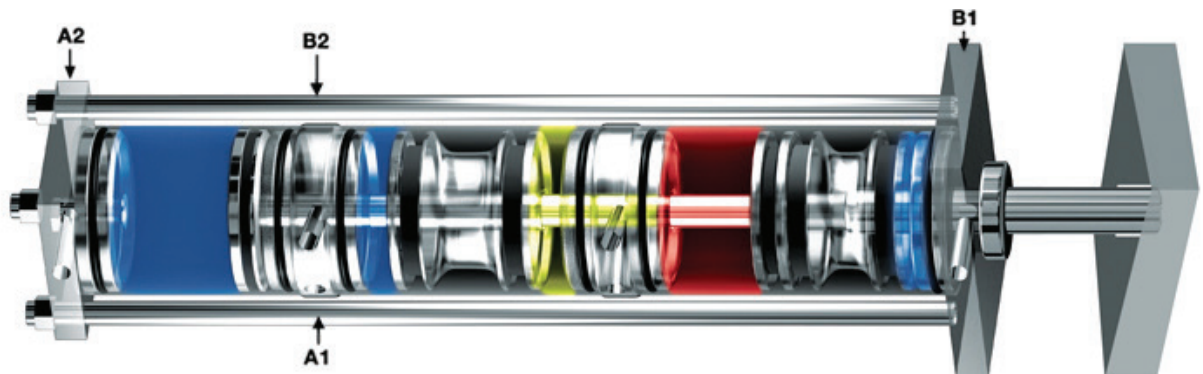

Figure 3. Power Stroke

Regulated air pressure is applied to port A2. High pressure piston and rod advance until contacting the valve block seal, isolating the reservoir oil from the oil contained in the working section. Continued movement intensifies and displaces the trapped oil, developing power stroke. Step 1 returns all three pistons and oil to the retracted position.

All BTM cylinders operate on a basis of ratios. Input air pressure (PSI) multiplied by the Working Ratio of a respective cylinder determines the cylinder Output Force.

Minimum Supply Air Pressure:

- Fast Approach: 50 PSI
- High Pressure: 30 PSI

Refer to the chart below for performance specifications.

Supply Air Pressure	30-100 PSI
Recommended Air Preparation	40 Micron Filtration, Lubricated
Operating Temperature	10° F - 160° F
Maximum Operating Speed	1.5 Foot/second
Usable Cylinder Service Life	20-30 million cycles (lubricated air)*
Recommended Replacement Oil <i>Please contact BTM prior to use of any other oils.</i>	Chevron ISO 32 Shell Tellus 22 ESSO Nuyo A22 Exxon Spinesstic 22 Mobil Velocite #10 Sunoco Sunvis 822

*Cylinders may require refilling of the internal oil reservoir at 3-6 million cycle intervals. Actual cylinder life may vary due to plant air supply condition and/or applications.



BTM In-line Cylinder Series



BTM Satellite Series

Model Series/Size	*Approach Force per (PSI)	*Retract Force per PSI	Minimum H.P Force @30 PSI (lbs.)	Maximum H.P Force @100 PSI (lbs.)	Working Ratio (Force per PSI)	Service Ratio (Hydraulic)	(1) Air Consumption per Cycle*
BTMCTL-I/S-1	3.14	2.35	670	2234	22.34:1	7:1	.136 SCFM
BTMCTL-I/S-2	4.90	4.11	1636	5454	54.54:1	11:1	.267 SCFM
BTMCTL-I/S-4	8.29	6.81	2628	8762	87.62:1	10:1	.426 SCFM
BTMCTL-I/S-8	12.56	10.81	4765	15,886	158.86:1	12.6:1	.886 SCFM
BTMCTL-I/S-10	19.63	16.49	7788	25,963	259.63:1	13:1	1.079 SCFM
BTMCTL-I/S-15	19.63	16.49	9424	31,416	314.16:1	16:1	1.356 SCFM
BTMCTL-I/S-20	19.63	16.49	11,635	38,785	387.85:1	19.7:1	1.568 SCFM
BTMCTL-I/S-30	28.27	23.37	19,543	65,144	651.44:1	23:1	2.510 SCFM
BTMCTL-I/S-50	50.26	43.20	31,503	105,044	1050.44:1	21:1	4.204 SCFM
BTMCTL-I/S-75	78.54	65.97	46,542	155,140	1551.40:1	19.8:1	7.160 SCFM
BTMCTL-I/S-100	78.54	65.97	58,905	196,358	1693.50:1	25:1	8.51 SCFM

NOTE: The above specifications are theoretical forces. Frictional loads and lack of proper air supply may affect cylinder performance. Please multiply application force requirements by 1.25-1.50 to ensure adequate force is available.

* Typical approach/retract break-away air pressure is 35 PSI.

(1) Air consumption values shown are based on 4.00" total stroke, .50" power stroke cylinder operating at 60 PSI. Multiply value by cycles per minute for total SCFM usage.

BTM can provide a detailed evaluation of the forces BTM required for your application. Please contact your local BTM Representative or BTM Technical Support for assistance.

- Piercing/punching applications may require a stripper spring(s) if "punch-thru" is prior to the end of cylinder stroke.
- All cylinders may be operated with non-lubricated air. However, cylinder service life will be reduced by 20%.
- For additional operational information, refer to "Installation Guidelines".

TABLE OF CONTENTS

BTM AIR/OIL CYLINDERS

BTM Cylinder In-line (I) Series	8-11
BTM Cylinder Satellite (S) Series	12-15

INTELLICYL FOR QUALITY CONTROL	16-17
---	-------

CYLINDER OPTIONS & ACCESSORIES

PSL Power Stroke Limiter	18
TSL Total Stroke Limiter	18
PB Pressure Block	18
IC-1 Pressure Coupling	18
GA-1 Gage Adapter Coupling	18
High Pressure Hose Assemblies	18
Hydraulic Gage Kits	18
HFP-1, HFP-2 Hyperfill Units	19
PT/ELT Sensors	19
Rod Lock Option	19
Die Set Couplings	19

PRESSURE SWITCHES

SW Pressure Switch	20
SWD Pressure Switch	20
Control Circuits	21

INSTALLATION GUIDELINES

All HPI, and HPS, Cylinders	22
-----------------------------------	----

HOW TO ORDER

BTM Cylinder In-line (I) Series	23
BTM Cylinder Satellite (S) Series	23

BTM IN-LINE CYLINDERS

The in-line cylinder is a totally self-contained, cost-effective power source ideally suited for a wide variety of assembly and forming applications. Available in sizes from 1 to 100 tons, up to 8.00" stroke, and .50" power stroke, the In-Line Series cylinders provide the greatest force per dollar invested.

Modifications such as rod end styles, port locations, approach and power stroke lengths are options available upon request. Please contact BTM for more information.



STANDARD FEATURES

- Total air/oil separation
- Linear force output
- Three moving components
- Simple control circuits
- 100,000 PSI tensile tie rods
- NFPA medium duty mounting styles
- Operation in any position or attitude
- 4.7 million MTBF (mean time between failure), 20 million service life
- Field serviceable-seal kits
- Fill units/repair manual
- Heavy-duty construction designed for years of trouble free use
- Numerous options, such as gage kits, sensors, press frames and bases.
- 3 year warranty

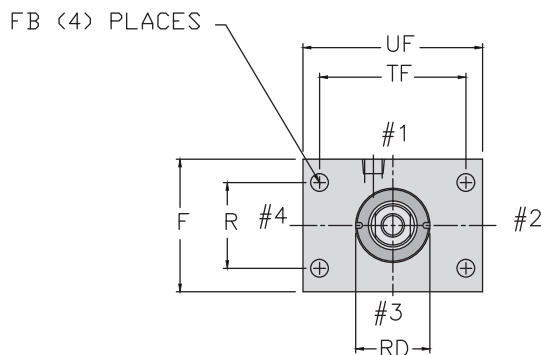
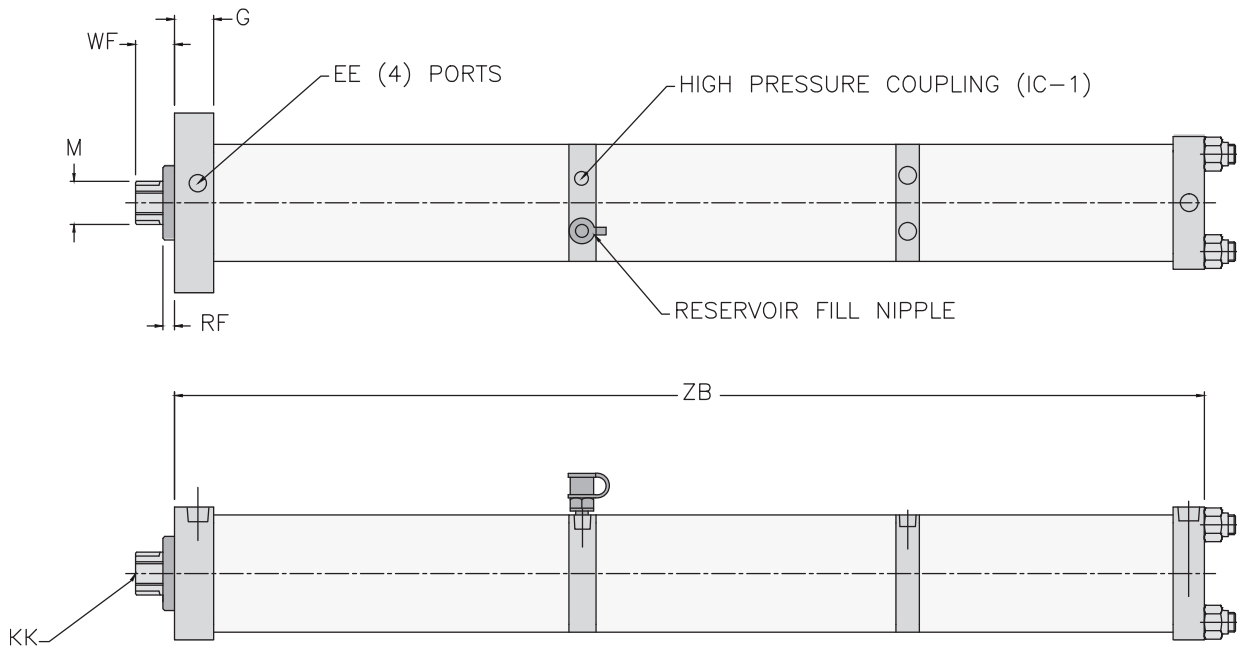

MOUNTING STYLE FH

NOTE: STANDARD CYLINDER PORTS AT POSITION #1.

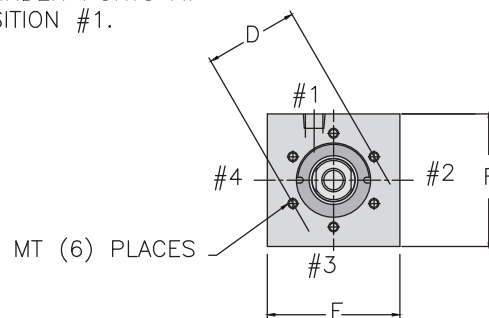

MOUNTING STYLE UH

HOW TO ORDER

NOTE: Options such as sensors, HyperFill Units and switches must be ordered separately. refer to pages 18-19.

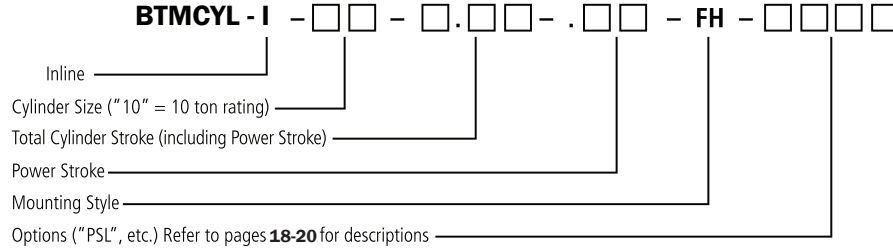

Model No.	Output Force per PSI (lbs.)	Approach/Retract per PSI (lbs.)	D	EE	F	FB	G	UF	TF	KK	M	MT	R	RD	RF	WF	ZB
BTM CYL-I-1-2.00-.25-FH	22.34	3.14/2.35	N/A	1/8" NPT	2.500 (63.50)	.440 (11.18)	1.250 (31.75)	4.250 (107.95)	3.438 (87.33)	3/4-16 1.0DP.	1.00 (25.40)	N/A	1.630 (41.40)	1.749 (44.42)	.380 (9.65)	1.250 (31.75)	20.207 (513.26)
BTM CYL-I-1-4.00-.25-FH	22.34	3.14/2.35	N/A	1/8" NPT	2.500 (63.50)	.440 (11.18)	1.250 (31.75)	4.250 (107.95)	3.438 (87.33)	3/4-16 1.0DP.	1.00 (25.40)	N/A	1.630 (41.40)	1.749 (44.42)	.380 (9.65)	1.250 (31.75)	27.280 (692.91)
BTM CYL-I-1-6.00-.25-FH	22.34	3.14/2.35	N/A	1/8" NPT	2.500 (63.50)	.440 (11.18)	1.250 (31.75)	4.250 (107.95)	3.438 (87.33)	3/4-16 1.0DP.	1.00 (25.40)	N/A	1.630 (41.40)	1.749 (44.42)	.380 (9.65)	1.250 (31.75)	34.260 (870.20)
BTM CYL-I-2-2.00-.25-FH	54.54	4.90/4.11	N/A	1/4" NPT	3.000 (76.20)	.440 (11.18)	1.250 (31.75)	5.125 (130.18)	4.125 (104.78)	3/4-16 1.0DP.	1.000 (25.40)	N/A	2.050 (52.07)	1.749 (44.42)	.380 (9.65)	1.250 (31.75)	21.289 (540.74)
BTM CYL-I-2-4.00-.50-FH	54.54	4.90/4.11	N/A	1/4" NPT	3.000 (76.20)	.440 (11.18)	1.250 (31.75)	5.125 (130.18)	4.125 (104.78)	3/4-16 1.0DP.	1.000 (25.40)	N/A	2.050 (52.07)	1.749 (44.42)	.380 (9.65)	1.250 (31.75)	30.925 (785.50)
BTM CYL-I-2-6.00-.50-FH	54.54	4.90/4.11	N/A	1/4" NPT	3.000 (76.20)	.440 (11.18)	1.250 (31.75)	5.125 (130.18)	4.125 (104.78)	3/4-16 1.0DP.	1.000 (25.40)	N/A	2.050 (52.07)	1.749 (44.42)	.380 (9.65)	1.250 (31.75)	37.780 (959.61)
BTM CYL-I-2-8.00-.50-FH	54.54	4.90/4.11	N/A	1/4" NPT	3.000 (76.20)	.440 (11.18)	1.250 (31.75)	5.125 (130.18)	4.125 (104.78)	3/4-16 1.0DP.	1.000 (25.40)	N/A	2.050 (52.07)	1.749 (44.42)	.380 (9.65)	1.250 (31.75)	44.638 (1133.81)
BTM CYL-I-4-2.00-.25-**	87.62	8.29/6.81	3.000 (76.20)	3/8" NPT	4.250 (107.95)	.562 (14.27)	1.250 (31.75)	5.750 (146.05)	4.688 (119.08)	3/4-16 1.0DP.	1.375 (34.93)	5/16-18 .75 DP.	2.750 (69.85)	2.374 (60.30)	.380 (9.65)	1.250 (31.75)	23.169 (588.49)
BTM CYL-I-4-4.00-.50-**	87.62	8.29/6.81	3.000 (76.20)	3/8" NPT	4.250 (107.95)	.562 (14.27)	1.250 (31.75)	5.750 (146.05)	4.688 (119.08)	3/4-16 1.0DP.	1.375 (34.93)	5/16-18 .75 DP.	2.750 (69.85)	2.374 (60.30)	.380 (9.65)	1.250 (31.75)	32.183 (817.45)
BTM CYL-I-4-6.00-.50-**	87.62	8.29/6.81	3.000 (76.20)	3/8" NPT	4.250 (107.95)	.562 (14.27)	1.250 (31.75)	5.750 (146.05)	4.688 (119.08)	3/4-16 1.0DP.	1.375 (34.93)	5/16-18 .75 DP.	2.750 (69.85)	2.374 (60.30)	.380 (9.65)	1.250 (31.75)	38.930 (988.82)
BTM CYL-I-4-8.00-.50-**	87.62	8.29/6.81	3.000 (76.20)	3/8" NPT	4.250 (107.95)	.562 (14.27)	1.250 (31.75)	5.750 (146.05)	4.688 (119.08)	3/4-16 1.0DP.	1.375 (34.93)	5/16-18 .75 DP.	2.750 (69.85)	2.374 (60.30)	.380 (9.65)	1.250 (31.75)	46.426 (1179.22)
BTM CYL-I-8-2.00-.25-**	158.86	12.56/11.08	3.999 (101.57)	3/8" NPT	5.000 (127.00)	.656 (16.66)	1.250 (31.75)	6.250 (158.75)	5.314 (134.98)	3/4-16 1.25 DP.	1.375 (34.93)	1/2-13 1.375 DP.	3.320 (84.33)	2.374 (60.30)	.380 (9.65)	1.250 (31.75)	24.973 (634.31)
BTM CYL-I-8-4.00-.50-**	158.86	12.56/11.08	3.999 (101.57)	3/8" NPT	5.000 (127.00)	.656 (16.66)	1.250 (31.75)	6.250 (158.75)	5.314 (134.98)	3/4-16 1.25 DP.	1.375 (34.93)	1/2-13 1.375 DP.	3.320 (84.33)	2.374 (60.30)	.380 (9.65)	1.250 (31.75)	34.956 (887.88)
BTM CYL-I-8-6.00-.50-**	158.86	12.56/11.08	3.999 (101.57)	3/8" NPT	5.000 (127.00)	.656 (16.66)	1.250 (31.75)	6.250 (158.75)	5.314 (134.98)	3/4-16 1.25 DP.	1.375 (34.93)	1/2-13 1.375 DP.	3.320 (84.33)	2.374 (60.30)	.380 (9.65)	1.250 (31.75)	41.779 (1061.19)
BTM CYL-I-8-8.00-.50-**	158.86	12.56/11.08	3.999 (101.57)	3/8" NPT	5.000 (127.00)	.656 (16.66)	1.250 (31.75)	6.250 (158.75)	5.314 (134.98)	3/4-16 1.25 DP.	1.375 (34.93)	1/2-13 1.375 DP.	3.320 (84.33)	2.374 (60.30)	.380 (9.65)	1.250 (31.75)	48.603 (1234.52)
BTM CYL-I-10-2.00-.25-**	259.63	19.63/16.49	4.250 (107.95)	1/2" NPT	6.500 (165.10)	.812 (20.62)	1.500 (38.10)	8.000 (203.20)	6.625 (168.28)	1 1/2-12 2.25 DP.	2.000 (50.80)	1/2-13 .75 DP.	4.100 (104.14)	2.999 (76.17)	.380 (9.65)	1.750 (44.45)	26.430 (671.32)
BTM CYL-I-10-4.00-.50-**	259.63	19.63/16.49	4.250 (107.95)	1/2" NPT	6.500 (165.10)	.812 (20.62)	1.500 (38.10)	8.000 (203.20)	6.625 (168.28)	1 1/2-12 2.25 DP.	2.000 (50.80)	1/2-13 .75 DP.	4.100 (104.14)	2.999 (76.17)	.380 (9.65)	1.750 (44.45)	36.437 (925.50)
BTM CYL-I-10-6.00-.50-**	259.63	19.63/16.49	4.250 (107.95)	1/2" NPT	6.500 (165.10)	.812 (20.62)	1.500 (38.10)	8.000 (203.20)	6.625 (168.28)	1 1/2-12 2.25 DP.	2.000 (50.80)	1/2-13 .75 DP.	4.100 (104.14)	2.999 (76.17)	.380 (9.65)	1.750 (44.45)	42.500 (1079.50)
BTM CYL-I-10-8.00-.50-**	259.63	19.63/16.49	4.250 (107.95)	1/2" NPT	6.500 (165.10)	.812 (20.62)	1.500 (38.10)	8.000 (203.20)	6.625 (168.28)	1 1/2-12 2.25 DP.	2.000 (50.80)	1/2-13 .75 DP.	4.100 (104.14)	2.999 (76.17)	.380 (9.65)	1.750 (44.45)	49.313 (1252.55)
BTM CYL-I-15-2.00-.25-**	314.08	19.63/16.49	4.250 (107.95)	1/2" NPT	6.500 (165.10)	.812 (20.62)	1.500 (38.10)	8.000 (203.20)	6.625 (168.28)	1 1/2-12 2.25 DP.	2.000 (50.80)	1/2-13 .75 DP.	4.100 (104.14)	3.000 (76.20)	.380 (9.65)	1.750 (44.45)	28.740 (730.00)
BTM CYL-I-15-4.00-.50-**	314.08	19.63/16.49	4.250 (107.95)	1/2" NPT	6.500 (165.10)	.812 (20.62)	1.500 (38.10)	8.000 (203.20)	6.625 (168.28)	1 1/2-12 2.25 DP.	2.000 (50.80)	1/2-13 .75 DP.	4.100 (104.14)	3.000 (76.20)	.380 (9.65)	1.750 (44.45)	40.505 (1028.83)
BTM CYL-I-15-6.00-.50-**	314.08	19.63/16.49	4.250 (107.95)	1/2" NPT	6.500 (165.10)	.812 (20.62)	1.500 (38.10)	8.000 (203.20)	6.625 (168.28)	1 1/2-12 2.25 DP.	2.000 (50.80)	1/2-13 .75 DP.	4.100 (104.14)	3.000 (76.20)	.380 (9.65)	1.750 (44.45)	43.530 (1105.66)
BTM CYL-I-15-8.00-.50-**	314.08	19.63/16.49	4.250 (107.95)	1/2" NPT	6.500 (165.10)	.812 (20.62)	1.500 (38.10)	8.000 (203.20)	6.625 (168.28)	1 1/2-12 2.25 DP.	2.000 (50.80)	1/2-13 .75 DP.	4.100 (104.14)	3.000 (76.20)	.380 (9.65)	1.750 (44.45)	51.488 (1307.80)

*Dimensions subject to change. Contact BTM for official drawings.
 ** UH of FH mounting configuration is standard.

IN-LINE CYLINDERS CONTINUED...

HOW TO ORDER

NOTE: Options such as sensors, HyperFill Units and switches must be ordered separately. refer to pages 18-19.

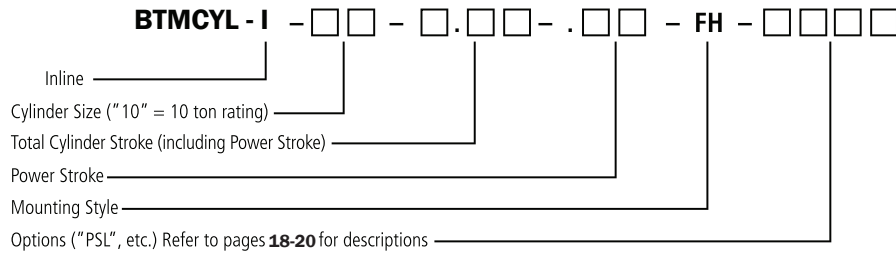

Model No.	Output Force per PSI (lbs.)	Approach/Retract per PSI (lbs.)	D	EE	F	FB	G	UF	TF	KK	M	MT	R	RD	RF	WF	ZB
BTM CYL-I-20-2.00-.25-**	387.85	19.63/16.49	4.250 (107.95)	1/2" NPT	6.500 (165.10)	.812 (20.62)	1.500 (38.10)	8.000 (203.20)	6.625 (168.28)	1 1/2-12 2.25 DP.	2.00 (50.80)	1/2-13 .75 DP.	4.100 (104.14)	3.000 (76.20)	.380 (9.65)	1.750 (44.45)	30.376 (771.55)
BTM CYL-I-20-4.00-.50-**	387.85	19.63/16.49	4.250 (107.95)	1/2" NPT	6.500 (165.10)	.812 (20.62)	1.500 (38.10)	8.000 (203.20)	6.625 (168.28)	1 1/2-12 2.25 DP.	2.00 (50.80)	1/2-13 .75 DP.	4.100 (104.14)	3.000 (76.20)	.380 (9.65)	1.750 (44.45)	44.000 (1117.60)
BTM CYL-I-20-6.00-.50-**	387.85	19.63/16.49	4.250 (107.95)	1/2" NPT	6.500 (165.10)	.812 (20.62)	1.500 (38.10)	8.000 (203.20)	6.625 (168.28)	1 1/2-12 2.25 DP.	2.00 (50.80)	1/2-13 .75 DP.	4.100 (104.14)	3.000 (76.20)	.380 (9.65)	1.750 (44.45)	47.910 (1216.91)
BTM CYL-I-20-8.00-.50-**	387.85	19.63/16.49	4.250 (107.95)	1/2" NPT	6.500 (165.10)	.812 (20.62)	1.500 (38.10)	8.000 (203.20)	6.625 (168.28)	1 1/2-12 2.25 DP.	2.00 (50.80)	1/2-13 .75 DP.	4.100 (104.14)	3.000 (76.20)	.380 (9.65)	1.750 (44.45)	53.167 (1350.44)
BTM CYL-I-30-2.00-.25-**	651.44	28.27/23.37	6.280 (159.51)	3/4" NPT	7.500 (190.50)	1.060 (26.92)	2.000 (50.80)	11.250 (285.75)	9.440 (239.78)	1 7/8-12 3.0 DP.	2.500 (63.50)	3/4-10 1.25 DP.	5.730 (145.54)	3.749 (95.22)	.500 (12.70)	1.750 (44.45)	34.939 (887.45)
BTM CYL-I-30-4.00-.50-**	651.44	28.27/23.37	6.280 (159.51)	3/4" NPT	7.500 (190.50)	1.060 (26.92)	2.000 (50.80)	11.250 (285.75)	9.440 (239.78)	1 7/8-12 3.0 DP.	2.500 (63.50)	3/4-10 1.25 DP.	5.730 (145.54)	3.749 (95.22)	.500 (12.70)	1.750 (44.45)	49.125 (1247.78)
BTM CYL-I-30-6.00-.50-**	651.44	28.27/23.37	6.280 (159.51)	3/4" NPT	7.500 (190.50)	1.060 (26.92)	2.000 (50.80)	11.250 (285.75)	9.440 (239.78)	1 7/8-12 3.0 DP.	2.500 (63.50)	3/4-10 1.25 DP.	5.730 (145.54)	3.749 (95.22)	.500 (12.70)	1.750 (44.45)	53.090 (1348.49)
BTM CYL-I-30-8.00-.50-**	651.44	28.27/23.37	6.280 (159.51)	3/4" NPT	7.500 (190.50)	1.060 (26.92)	2.000 (50.80)	11.250 (285.75)	9.440 (239.78)	1 7/8-12 3.0 DP.	2.500 (63.50)	3/4-10 1.25 DP.	5.730 (145.54)	3.749 (95.22)	.500 (12.70)	1.750 (44.45)	56.811 (1443.00)
BTM CYL-I-50-2.00-.25-FH	1050.44	50.26/43.20	N/A	3/4" NPT	11.000 (279.40)	1.312 (33.32)	2.000 (50.80)	15.500 (393.70)	13.250 (336.55)	2 1/4-12 3.5 DP.	3.000 (76.20)	N/A	8.500 (215.90)	4.300 (109.22)	.500 (12.70)	2.000 (50.80)	35.710 (907.03)
BTM CYL-I-50-4.00-.50-FH	1050.44	50.26/43.20	N/A	3/4" NPT	11.000 (279.40)	1.312 (33.32)	2.000 (50.80)	15.500 (393.70)	13.250 (336.55)	2 1/4-12 3.5 DP.	3.000 (76.20)	N/A	8.500 (215.90)	4.300 (109.22)	.500 (12.70)	2.000 (50.80)	48.548 (1233.12)
BTM CYL-I-50-6.00-.50-FH	1050.44	50.26/43.20	N/A	3/4" NPT	11.000 (279.40)	1.312 (33.32)	2.000 (50.80)	15.500 (393.70)	13.250 (336.55)	2 1/4-12 3.5 DP.	3.000 (76.20)	N/A	8.500 (215.90)	4.300 (109.22)	.500 (12.70)	2.000 (50.80)	53.350 (1355.09)
BTM CYL-I-50-8.00-.50-FH	1050.44	50.26/43.20	N/A	3/4" NPT	11.000 (279.40)	1.312 (33.32)	2.000 (50.80)	15.500 (393.70)	13.250 (336.55)	2 1/4-12 3.5 DP.	3.000 (76.20)	N/A	8.500 (215.90)	4.300 (109.22)	.500 (12.70)	2.000 (50.80)	57.100 (1450.34)
BTM CYL-I-75-2.00-.25-**	1551.40	78.54/65.97	N/A	3/4" NPT	14.000 (355.60)	1.812 (46.02)	3.000 (76.20)	19.000 (482.60)	15.875 (403.23)	2-1/4-12 3.0 DP.	4.000 (101.60)	N/A	9.620 (244.35)	5.251 (133.38)	.500 (12.70)	1.750 (44.45)	36.680 (931.67)
BTM CYL-I-75-4.00-.50-**	1551.40	78.54/65.97	N/A	3/4" NPT	14.000 (355.60)	1.812 (46.02)	3.000 (76.20)	19.000 (482.60)	15.875 (403.23)	2-1/4-12 3.0 DP.	4.000 (101.60)	N/A	9.620 (244.35)	5.251 (133.38)	.500 (12.70)	1.750 (44.45)	49.733 (1263.22)
BTM CYL-I-75-6.00-.50-**	1551.40	78.54/65.97	N/A	3/4" NPT	14.000 (355.60)	1.812 (46.02)	3.000 (76.20)	19.000 (482.60)	15.875 (403.23)	2-1/4-12 3.0 DP.	4.000 (101.60)	N/A	9.620 (244.35)	5.251 (133.38)	.500 (12.70)	1.750 (44.45)	53.472 (1358.19)
BTM CYL-I-75-8.00-.50-**	1551.40	78.54/65.97	N/A	3/4" NPT	14.000 (355.60)	1.812 (46.02)	3.000 (76.20)	19.000 (482.60)	15.875 (403.23)	2-1/4-12 3.0 DP.	4.000 (101.60)	N/A	9.620 (244.35)	5.251 (133.38)	.500 (12.70)	1.750 (44.45)	57.348 (1456.64)
BTM CYL-I-100-2.00-.25-**	1963.5	78.54/65.97	N/A	3/4" NPT	14.000 (355.60)	1.812 (46.02)	3.000 (76.20)	19.000 (482.60)	15.875 (403.23)	2-1/4-12 3.0 DP.	4.000 (101.60)	N/A	9.620 (244.35)	5.251 (133.38)	.500 (12.70)	1.750 (44.45)	39.298 (998.17)
BTM CYL-I-100-4.00-.50-**	1963.5	78.54/65.97	N/A	3/4" NPT	14.000 (355.60)	1.812 (46.02)	3.000 (76.20)	19.000 (482.60)	15.875 (403.23)	2-1/4-12 3.0 DP.	4.000 (101.60)	N/A	9.620 (244.35)	5.251 (133.38)	.500 (12.70)	1.750 (44.45)	55.445 (1408.30)
BTM CYL-I-100-6.00-.50-**	1963.5	78.54/65.97	N/A	3/4" NPT	14.000 (355.60)	1.812 (46.02)	3.000 (76.20)	19.000 (482.60)	15.875 (403.23)	2-1/4-12 3.0 DP.	4.000 (101.60)	N/A	9.620 (244.35)	5.251 (133.38)	.500 (12.70)	1.750 (44.45)	58.653 (1489.79)
BTM CYL-I-100-8.00-.50-**	1963.5	78.54/65.97	N/A	3/4" NPT	14.000 (355.60)	1.812 (46.02)	3.000 (76.20)	19.000 (482.60)	15.875 (403.23)	2-1/4-12 3.0 DP.	4.000 (101.60)	N/A	9.620 (244.35)	5.251 (133.38)	.500 (12.70)	1.750 (44.45)	62.361 (1583.97)

*Dimensions subject to change. Contact BTM for official drawings.
 ** UH of FH mounting configuration is standard.

IN-LINE CYLINDERS ENGINEERING DATA

Air Pressure (PSI)	BTMCTL-I-1 Ton series	BTMCTL-I-2 Ton series	BTMCTL-I-4 Ton series	BTMCTL-I-8 Ton series	BTMCTL-I-10 Ton series	BTMCTL-I-15 Ton series	BTMCTL-I-20 Ton series	BTMCTL-I-30 Ton series	BTMCTL-I-50 Ton series	BTMCTL-I-75 Ton series	BTMCTL-I-100 Ton series
	Hyd PSI/Force lb.	Hyd PSI/Force lb.	Hyd PSI/Force lb.	Hyd PSI/Force lb.	Hyd PSI/Force lb.	Hyd PSI/Force lb.	Hyd PSI/Force lb.	Hyd PSI/Force lb.	Hyd PSI/Force lb.	Hyd PSI/Force lb.	Hyd PSI/Force lb.
30	210/670	330/16360	316/2626	379/4766	396/7785	480/9422	591/11601	651/19540	630/31663	592/46542	750/58905
40	280/893	440/2181	422/3501	506/6355	528/10380	644/12641	788/15468	921/26053	840/42218	790/62056	1000/78540
50	350/1117	550/2727	528/4377	632/7943	661/12975	805/15802	985/19335	1152/32567	1050/52773	987/77570	1250/98175
60	420/1340	660/3272	633/5252	758/9532	793/15570	966/18962	1182/23202	1382/39080	1260/63327	1185/93084	1500/117810
70	490/1563	770/3817	739/6127	885/11120	925/18165	1127/22123	1379/27069	1612/45593	1470/73882	1382/108598	1750/137445
80	560/1787	880/4363	844/7003	1011/12709	1057/20760	1288/25283	1576/30936	1843/52107	1680/84436	1580/124112	2000/157080
90	630/2010	990/4908	950/7878	1137/14298	1189/23355	1449/28443	1773/34803	2073/58620	1890/94991	1777/139626	2250/176715
100	700/2234	1100/5454	1056/8754	1264/15886	1322/25950	1600/31408	1970/38671	2304/65134	2100/105546	1975/155140	2500/196350

*Typical cylinder break-away pressure is 35 PSI.

(1) Complete cylinder cycle @ 60 PSI.

Multiply value by cycles per minute for total SCFM usage.

NOTE: The above specifications are theoretical forces. Frictional loads and lack of proper air supply may affect cylinder performance.

Please multiply application force requirements by 1.25-1.50 to ensure adequate force is available.

	BTMCTL-I-1 Ton series	BTMCTL-I-2 Ton series	BTMCTL-I-4 Ton series	BTMCTL-I-8 Ton series	BTMCTL-I-10 Ton series	BTMCTL-I-15 Ton series	BTMCTL-I-20 Ton series	BTMCTL-I-30 Ton series	BTMCTL-I-50 Ton series	BTMCTL-I-75 Ton series	BTMCTL-I-100 Ton series
Approach Force per PSI (lbs.)	*3.14	*4.90	*8.29	*12.56	*19.63	*19.63	*19.63	*28.27	*50.26	*78.54	*78.54
Retract Force per PSI (lbs.)	*2.35	*4.11	*6.81	*11.08	*16.49	*16.49	*16.49	*23.37	*43.20	*65.97	*65.97
Output Force Range (lbs.)	670-2234	1636-5454	2626-8754	4766-15,886	7785-25,950	9424-31,408	11,635-38,785	19,540-65,134	31,663-105,546	46,542-155,140	58,905-196,350
Working Ratio (Output per PSI (lbs.))	22.34:1	54.54:1	87.62:1	158.86:1	259.62:1	314.08:1	387.85:1	651.44:1	1055.46:1	1551.40:1	1963.5:1
Service Ratio (Hydraulic PSI (lbs.))	7:01	11:1	10.56:1	12.64:1	13.22:1	16:1	19.7:1	23.04:1	21:1	19.8:1	25:1
Air Consumption per Cycle	.136 SCFM(1)	.267 SCFM(1)	.426 SCFM(1)	1.079 SCFM(1)	1.079 SCFM(1)	1.356 SCFM(1)	1.568 SCFM(1)	2.510 SCFM(1)	4.204 SCFM(1)	7.160 SCFM(1)	8.51 SCFM(1)
Operating Temperature	10°F-160°F	10°F-160°F	10°F-160°F	10°F-160°F	10°F-160°F	10°F-160°F	10°F-160°F	10°F-160°F	10°F-160°F	10°F-160°F	10°F-160°F
Maximum Operating Speed ***	1.5 Ft/sec	1.5 Ft/sec	1.5 Ft/sec	1.5 Ft/sec	1.5 Ft/sec	1.5 Ft/sec	1.5 Ft/sec	1.5 Ft/sec	1.5 Ft/sec	1.5 Ft/sec	1.5 Ft/sec
Recommended Air Filter	40 Micron	40 Micron	40 Micron	40 Micron	40 Micron	40 Micron	40 Micron	40 Micron	40 Micron	40 Micron	40 Micron
Maximum Operating Pressure	100 PSI	100 PSI	100 PSI	100 PSI	100 PSI	100 PSI	100 PSI	100 PSI	100 PSI	100 PSI	100 PSI
Minimum Operating Pressure	30 PSI	30 PSI	30 PSI	30 PSI	30 PSI	30 PSI	30 PSI	30 PSI	30 PSI	30 PSI	30 PSI

*Typical cylinder break-away pressure is 35 PSI.

(1) Complete cylinder cycle @ 60 PSI.

Multiply value by cycles per minute for total SCFM usage.

*** Maximum speed of the seals (not maximum speed of cylinder).

NOTE: The above specifications are theoretical forces. Frictional loads and lack of proper air supply may affect cylinder performance.

Please multiply application force requirements by 1.25-1.50 to ensure adequate force is available.

BTM SATELLITE SERIES CYLINDERS

The satellite cylinder is a totally self-contained, cost-effective power source ideally suited for a wide variety of assembly and forming applications. Available in sizes from 1 to 100 tons, up to 8.00" stroke, and 1.00" power stroke, the HPS Series cylinder design provides a very compact package where space is limited.

The Satellite Series of cylinders permit the working cylinder to be located up to 10 ft. from the booster/reservoir section. Both components may be mounted in any position or attitude. Multiple working cylinders can also be operated with a single booster/reservoir unit.

Modifications such as rod end styles, port locations, approach and power stroke lengths are options available upon request. Please contact BTM for more information.

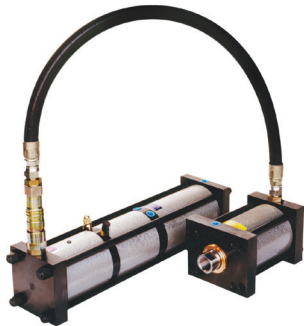

STANDARD FEATURES

- Total air/oil separation
- Linear force output
- Three moving components
- Internal shock pads
- Fill and high pressure gage couplings
- Hose assembly and disconnect
- Two mounting styles
- Simple control circuits
- 100,000 PSI tensile tie rods
- NFPA medium duty mounting styles
- Operation in any position or attitude
- 4.7 million MTBF, 20 million service life
- Field serviceable-seal kits
- Fill units/repair manual
- Heavy-duty construction designed for years of trouble free use
- Numerous options, such as gage kits, sensors, press frames and bases.
- 3 year warranty

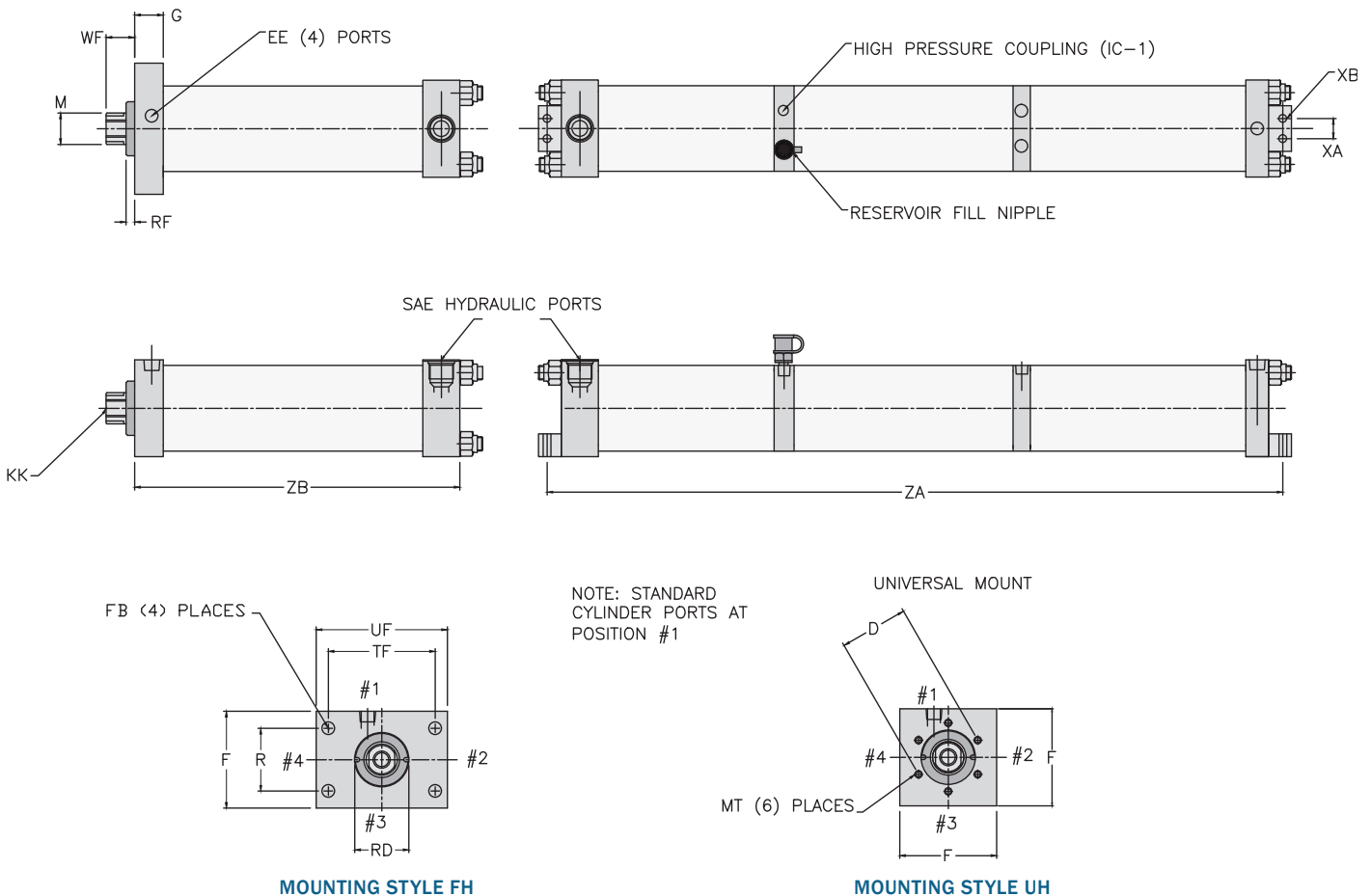

HOW TO ORDER

NOTE: Options such as sensors, HyperFill Units and switches must be ordered separately. refer to pages 18-19.

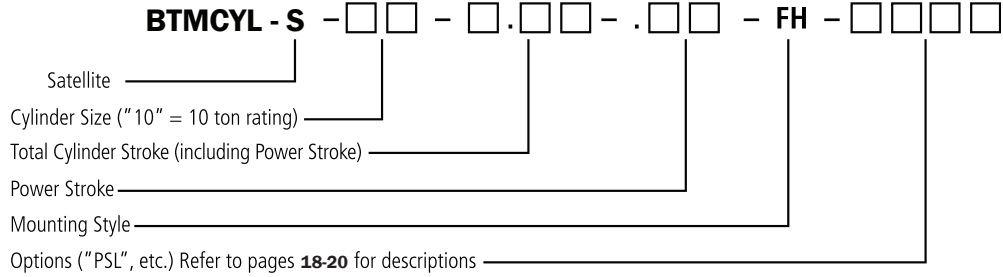

All Satellite Series cylinders are pre-filled and include a hose assembly and "dry-break" style hydraulic disconnect. Standard hydraulic fittings are straight SAE connections on both work cylinder and reservoir/booster unit.

Model No.	D	EE	F	FB	G	UF	TF	KK	M	MT	R	RD	RF	WF	ZB	ZA	XA	XB
BTM CYL-S-1-2.00-.25-FH	N/A	1/8" NPT	2.500 (63.50)	.440 (11.18)	1.250 (31.75)	4.250 (107.95)	3.438 (87.33)	3/4-16 1.0 DP.	1.00 (25.40)	N/A	1.630 (41.40)	1.749 (44.42)	.380 (9.65)	1.250 (31.75)	9.250 (234.95)	18.607 (472.62)	.6250 (15.88)	.281 (7.14)
BTM CYL-S-1-4.00-.50-FH	N/A	1/8" NPT	2.500 (63.50)	.440 (11.18)	1.250 (31.75)	4.250 (107.95)	3.438 (87.33)	3/4-16 1.0 DP.	1.00 (25.40)	N/A	1.630 (41.40)	1.749 (44.42)	.380 (9.65)	1.250 (31.75)	13.280 (337.31)	21.507 (546.28)	.6250 (15.88)	.281 (7.14)
BTM CYL-S-1-6.00-.50-FH	N/A	1/8" NPT	2.500 (63.50)	.440 (11.18)	1.250 (31.75)	4.250 (107.95)	3.438 (87.33)	3/4-16 1.0 DP.	1.00 (25.40)	N/A	1.630 (41.40)	1.749 (44.42)	.380 (9.65)	1.250 (31.75)	17.280 (438.91)	24.533 (623.14)	.6250 (15.88)	.281 (7.14)
BTM CYL-S-1-8.00-.50-FH	N/A	1/8" NPT	2.500 (63.50)	.440 (11.18)	1.250 (31.75)	4.250 (107.95)	3.438 (87.33)	3/4-16 1.0 DP.	1.00 (25.40)	N/A	1.630 (41.40)	1.749 (44.42)	.380 (9.65)	1.250 (31.75)	21.250 (539.75)	31.239 (793.47)	.6250 (15.88)	.281 (7.14)
BTM CYL-S-2-2.00-.25-FH	N/A	1/4" NPT	3.000 (76.20)	.440 (11.18)	1.250 (31.75)	5.125 (130.18)	4.125 (104.78)	3/4-16 1.0 DP.	1.00 (25.40)	N/A	2.050 (52.07)	1.749 (44.42)	.380 (9.65)	1.250 (31.75)	9.281 (235.74)	21.753 (552.53)	1.000 (25.40)	.343 (8.71)
BTM CYL-S-2-4.00-.50-FH	N/A	1/4" NPT	3.000 (76.20)	.440 (11.18)	1.250 (31.75)	5.125 (130.18)	4.125 (104.78)	3/4-16 1.0 DP.	1.00 (25.40)	N/A	2.050 (52.07)	1.749 (44.42)	.380 (9.65)	1.250 (31.75)	13.281 (337.34)	30.166 (766.22)	1.000 (25.40)	.343 (8.71)
BTM CYL-S-2-6.00-.50-FH	N/A	1/4" NPT	3.000 (76.20)	.440 (11.18)	1.250 (31.75)	5.125 (130.18)	4.125 (104.78)	3/4-16 1.0 DP.	1.00 (25.40)	N/A	2.050 (52.07)	1.749 (44.42)	.380 (9.65)	1.250 (31.75)	17.280 (438.91)	33.020 (838.71)	1.000 (25.40)	.343 (8.71)
BTM CYL-S-2-8.00-1.00-FH	N/A	1/4" NPT	3.000 (76.20)	.440 (11.18)	1.250 (31.75)	5.125 (130.18)	4.125 (104.78)	3/4-16 1.0 DP.	1.00 (25.40)	N/A	2.050 (52.07)	1.749 (44.42)	.380 (9.65)	1.250 (31.75)	21.281 (540.54)	46.992 (1193.60)	1.000 (25.40)	.343 (8.71)
BTM CYL-S-4-2.00-.25-**	3.000 (76.20)	3/8" NPT	4.250 (107.95)	.562 (14.27)	1.250 (31.75)	5.750 (146.05)	4.688 (119.08)	3/4-16 1.0 DP.	1.375 (34.93)	5/16-18 .75 DP.	2.750 (69.85)	2.374 (60.30)	.380 (9.65)	1.250 (31.75)	10.250 (260.35)	23.230 (590.04)	1.500 (38.10)	.343 (8.71)
BTM CYL-S-4-4.00-.50-**	3.000 (76.20)	3/8" NPT	4.250 (107.95)	.562 (14.27)	1.250 (31.75)	5.750 (146.05)	4.688 (119.08)	3/4-16 1.0 DP.	1.375 (34.93)	5/16-18 .75 DP.	2.750 (69.85)	2.374 (60.30)	.380 (9.65)	1.250 (31.75)	14.250 (361.95)	31.378 (797.00)	1.500 (38.10)	.343 (8.71)
BTM CYL-S-4-6.00-.50-**	3.000 (76.20)	3/8" NPT	4.250 (107.95)	.562 (14.27)	1.250 (31.75)	5.750 (146.05)	4.688 (119.08)	3/4-16 1.0 DP.	1.375 (34.93)	5/16-18 .75 DP.	2.750 (69.85)	2.374 (60.30)	.380 (9.65)	1.250 (31.75)	18.250 (463.55)	34.250 (869.95)	1.500 (38.10)	.343 (8.71)
BTM CYL-S-4-8.00-1.00-**	3.000 (76.20)	3/8" NPT	4.250 (107.95)	.562 (14.27)	1.250 (31.75)	5.750 (146.05)	4.688 (119.08)	3/4-16 1.0 DP.	1.375 (34.93)	5/16-18 .75 DP.	2.750 (69.85)	2.374 (60.30)	.380 (9.65)	1.250 (31.75)	22.250 (565.15)	47.624 (1209.65)	1.500 (38.10)	.343 (8.71)
BTM CYL-S-8-2.00-.25-**	3.999 (101.57)	3/8" NPT	5.000 (127.00)	.656 (16.66)	1.250 (31.75)	6.250 (158.75)	5.314 (134.98)	3/4-16 1.75 DP.	1.375 (34.93)	1/2-13 .75 DP.	3.320 (84.33)	2.374 (60.30)	.380 (9.65)	1.250 (31.75)	10.502 (266.75)	25.968 (659.59)	1.500 (38.10)	.343 (8.71)
BTM CYL-S-8-4.00-.50-**	3.999 (101.57)	3/8" NPT	5.000 (127.00)	.656 (16.66)	1.250 (31.75)	6.250 (158.75)	5.314 (134.98)	3/4-16 1.75 DP.	1.375 (34.93)	1/2-13 .75 DP.	3.320 (84.33)	2.374 (60.30)	.380 (9.65)	1.250 (31.75)	14.502 (368.35)	36.646 (930.81)	1.500 (38.10)	.343 (8.71)
BTM CYL-S-8-6.00-.50-**	3.999 (101.57)	3/8" NPT	5.000 (127.00)	.656 (16.66)	1.250 (31.75)	6.250 (158.75)	5.314 (134.98)	3/4-16 1.75 DP.	1.375 (34.93)	1/2-13 .75 DP.	3.320 (84.33)	2.374 (60.30)	.380 (9.65)	1.250 (31.75)	18.502 (469.95)	38.475 (977.27)	1.500 (38.10)	.343 (8.71)
BTM CYL-S-8-8.00-1.00-**	3.999 (101.57)	3/8" NPT	5.000 (127.00)	.656 (16.66)	1.250 (31.75)	6.250 (158.75)	5.314 (134.98)	3/4-16 1.75 DP.	1.375 (34.93)	1/2-13 .75 DP.	3.320 (84.33)	2.374 (60.30)	.380 (9.65)	1.250 (31.75)	22.502 (571.55)	53.943 (1370.15)	1.500 (38.10)	.343 (8.71)
BTM CYL-S-10-2.00-.25-**	4.250 (107.95)	1/2" NPT	6.500 (165.10)	.812 (20.62)	1.500 (38.10)	8.000 (203.20)	6.625 (168.28)	1-1/2 - 12 2.25 DP.	2.000 (50.80)	1/2-13 .75 DP.	4.100 (104.14)	2.999 (76.17)	.380 (9.65)	1.750 (44.45)	10.810 (274.57)	27.540 (699.52)	1.500 (38.10)	.343 (8.71)
BTM CYL-S-10-4.00-.50-**	4.250 (107.95)	1/2" NPT	6.500 (165.10)	.812 (20.62)	1.500 (38.10)	8.000 (203.20)	6.625 (168.28)	1-1/2 - 12 2.25 DP.	2.000 (50.80)	1/2-13 .75 DP.	4.100 (104.14)	2.999 (76.17)	.380 (9.65)	1.750 (44.45)	14.810 (376.17)	36.965 (938.91)	1.500 (38.10)	.343 (8.71)
BTM CYL-S-10-6.00-.50-**	4.250 (107.95)	1/2" NPT	6.500 (165.10)	.812 (20.62)	1.500 (38.10)	8.000 (203.20)	6.625 (168.28)	1-1/2 - 12 2.25 DP.	2.000 (50.80)	1/2-13 .75 DP.	4.100 (104.14)	2.999 (76.17)	.380 (9.65)	1.750 (44.45)	18.810 (477.77)	39.790 (1010.67)	1.500 (38.10)	.343 (8.71)
BTM CYL-S-10-8.00-1.00-**	4.250 (107.95)	1/2" NPT	6.500 (165.10)	.812 (20.62)	1.500 (38.10)	8.000 (203.20)	6.625 (168.28)	1-1/2 - 12 2.25 DP.	2.000 (50.80)	1/2-13 .75 DP.	4.100 (104.14)	2.999 (76.17)	.380 (9.65)	1.750 (44.45)	22.810 (579.37)	55.827 (1418.01)	1.500 (38.10)	.343 (8.71)
BTM CYL-S-15-2.00-.25-**	4.250 (107.95)	1/2" NPT	6.500 (165.10)	.812 (20.62)	1.500 (38.10)	8.000 (203.20)	6.625 (168.28)	1-1/2 - 12 2.25 DP.	2.000 (50.80)	1/2-13 .75 DP.	4.100 (104.14)	3.000 (76.20)	.380 (9.65)	1.750 (44.45)	10.810 (274.57)	29.461 (748.31)	1.500 (38.10)	.343 (8.71)
BTM CYL-S-15-4.00-.50-**	4.250 (107.95)	1/2" NPT	6.500 (165.10)	.812 (20.62)	1.500 (38.10)	8.000 (203.20)	6.625 (168.28)	1-1/2 - 12 2.25 DP.	2.000 (50.80)	1/2-13 .75 DP.	4.100 (104.14)	3.000 (76.20)	.380 (9.65)	1.750 (44.45)	14.810 (376.17)	40.247 (1022.27)	1.500 (38.10)	.343 (8.71)
BTM CYL-S-15-6.00-.50-**	4.250 (107.95)	1/2" NPT	6.500 (165.10)	.812 (20.62)	1.500 (38.10)	8.000 (203.20)	6.625 (168.28)	1-1/2 - 12 2.25 DP.	2.000 (50.80)	1/2-13 .75 DP.	4.100 (104.14)	3.000 (76.20)	.380 (9.65)	1.750 (44.45)	18.810 (477.77)	43.020 (1092.71)	1.500 (38.10)	.343 (8.71)
BTM CYL-S-15-8.00-1.00-**	4.250 (107.95)	1/2" NPT	6.500 (165.10)	.812 (20.62)	1.500 (38.10)	8.000 (203.20)	6.625 (168.28)	1-1/2 - 12 2.25 DP.	2.000 (50.80)	1/2-13 .75 DP.	4.100 (104.14)	3.000 (76.20)	.380 (9.65)	1.750 (44.45)	22.810 (579.37)	61.794 (1569.57)	1.500 (38.10)	.343 (8.71)

Model numbers shown are standard cylinders. Other cylinder stroke lengths are available in .50" increments, power stroke lengths in .125" increments.

Dimensions shown in inches with metric beneath (mm).

**UH of FH mounting configuration is standard.

SATELLITE SERIES CYLINDERS CONTINUED...

HOW TO ORDER

NOTE: Options such as sensors, HyperFill Units and switches must be ordered separately. refer to pages 18-19.

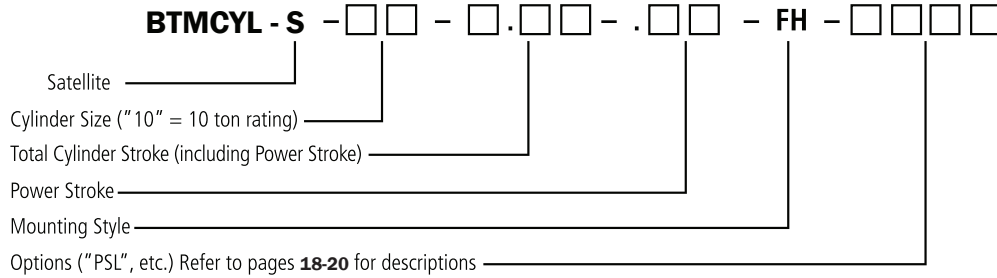

Model No.	D	EE	F	FB	G	UF	TF	KK	M	MT	R	RD	RF	WF	ZB	ZA	XA	XB
BTMCTL-S-20-2.00-.25-**-	4.250 (107.95)	1/2" NPT	6.500 (165.10)	.812 (20.62)	1.500 (38.10)	8.000 (203.20)	6.625 (168.28)	1-1/2 - 12 2.25 DP.	2.000 (50.80)	1/2-13 .75 DP.	4.100 (104.14)	3.000 (76.20)	.380 (9.65)	1.750 (44.45)	10.810 (274.57)	32.104 (815.44)	1.500 (38.10)	.343 (8.71)
BTMCTL-S-20-4.00-.50-**-	4.250 (107.95)	1/2" NPT	6.500 (165.10)	.812 (20.62)	1.500 (38.10)	8.000 (203.20)	6.625 (168.28)	1-1/2 - 12 2.25 DP.	2.000 (50.80)	1/2-13 .75 DP.	4.100 (104.14)	3.000 (76.20)	.380 (9.65)	1.750 (44.45)	14.810 (376.17)	44.732 (1136.19)	1.500 (38.10)	.343 (8.71)
BTMCTL-S-20-6.00-.50-**-	4.250 (107.95)	1/2" NPT	6.500 (165.10)	.812 (20.62)	1.500 (38.10)	8.000 (203.20)	6.625 (168.28)	1-1/2 - 12 2.25 DP.	2.000 (50.80)	1/2-13 .75 DP.	4.100 (104.14)	3.000 (76.20)	.380 (9.65)	1.750 (44.45)	18.810 (477.77)	47.470 (1205.74)	1.500 (38.10)	.343 (8.71)
BTMCTL-S-20-8.00-1.00-**-	4.250 (107.95)	1/2" NPT	6.500 (165.10)	.812 (20.62)	1.500 (38.10)	8.000 (203.20)	6.625 (168.28)	1-1/2 - 12 2.25 DP.	2.000 (50.80)	1/2-13 .75 DP.	4.100 (104.14)	3.000 (76.20)	.380 (9.65)	1.750 (44.45)	22.810 (579.37)	69.963 (1777.06)	1.500 (38.10)	.343 (8.71)
BTMCTL-S-30-2.00-.25-**-	6.280 (159.51)	3/4" NPT	7.500 (190.50)	1.06 (26.92)	2.000 (50.80)	11.250 (285.75)	9.440 (239.78)	1-7/8 - 12 3.0 DP.	2.500 (63.50)	3/4-10 1.25 DP.	5.730 (145.54)	3.749 (95.22)	.500 (12.70)	1.750 (44.45)	12.400 (314.96)	30.200 (767.08)	1.500 (38.10)	.343 (8.71)
BTMCTL-S-30-4.00-.50-**-	6.280 (159.51)	3/4" NPT	7.500 (190.50)	1.06 (26.92)	2.000 (50.80)	11.250 (285.75)	9.440 (239.78)	1-7/8 - 12 3.0 DP.	2.500 (63.50)	3/4-10 1.25 DP.	5.730 (145.54)	3.749 (95.22)	.500 (12.70)	1.750 (44.45)	16.400 (416.56)	51.500 (1308.10)	1.500 (38.10)	.343 (8.71)
BTMCTL-S-30-6.00-.50-**-	6.280 (159.51)	3/4" NPT	7.500 (190.50)	1.06 (26.92)	2.000 (50.80)	11.250 (285.75)	9.440 (239.78)	1-7/8 - 12 3.0 DP.	2.500 (63.50)	3/4-10 1.25 DP.	5.730 (145.54)	3.749 (95.22)	.500 (12.70)	1.750 (44.45)	20.410 (518.41)	54.240 (1377.70)	1.500 (38.10)	.343 (8.71)
BTMCTL-S-30-8.00-1.00-**-	6.280 (159.51)	3/4" NPT	7.500 (190.50)	1.06 (26.92)	2.000 (50.80)	11.250 (285.75)	9.440 (239.78)	1-7/8 - 12 3.0 DP.	2.500 (63.50)	3/4-10 1.25 DP.	5.730 (145.54)	3.749 (95.22)	.500 (12.70)	1.750 (44.45)	24.400 (619.76)	79.980 (2031.49)	1.500 (38.10)	.343 (8.71)
BTMCTL-S-50-2.00-.25-**-	N/A	3/4" NPT	11.000 (279.4)	1.312 (33.32)	2.000 (50.80)	15.500 (393.70)	13.250 (336.55)	2-1/4 - 12 3.5 DP.	3.000 (76.20)	N/A	8.500 (215.90)	4.300 (109.22)	.500 (12.70)	2.000 (50.80)	12.750 (323.85)	37.140 (943.36)	1.500 (38.10)	.410 (10.41)
BTMCTL-S-50-4.00-.50-**-	N/A	3/4" NPT	11.000 (279.4)	1.312 (33.32)	2.000 (50.80)	15.500 (393.70)	13.250 (336.55)	2-1/4 - 12 3.5 DP.	3.000 (76.20)	N/A	8.500 (215.90)	4.300 (109.22)	.500 (12.70)	2.000 (50.80)	16.750 (425.45)	50.320 (1278.13)	1.500 (38.10)	.410 (10.41)
BTMCTL-S-50-6.00-.50-**-	N/A	3/4" NPT	11.000 (279.4)	1.312 (33.32)	2.000 (50.80)	15.500 (393.70)	13.250 (336.55)	2-1/4 - 12 3.5 DP.	3.000 (76.20)	N/A	8.500 (215.90)	4.300 (109.22)	.500 (12.70)	2.000 (50.80)	20.750 (527.05)	53.050 (1347.47)	1.500 (38.10)	.410 (10.41)
BTMCTL-S-50-8.00-1.00-**-	N/A	3/4" NPT	11.000 (279.4)	1.312 (33.32)	2.000 (50.80)	15.500 (393.70)	13.250 (336.55)	2-1/4 - 12 3.5 DP.	3.000 (76.20)	N/A	8.500 (215.90)	4.300 (109.22)	.500 (12.70)	2.000 (50.80)	24.750 (628.65)	76.680 (1947.67)	1.500 (38.10)	.410 (10.41)
BTMCTL-S-75-2.00-.25-**-	N/A	3/4" NPT	14.000 (355.60)	1.812 (46.02)	3.000 (76.20)	19.000 (482.60)	15.875 (403.23)	2-1/4 - 12 3.0 DP.	4.000 (101.60)	N/A	9.620 (244.35)	5.251 (133.38)	.500 (12.70)	1.750 (44.45)	13.068 (331.93)	37.117 (942.77)	1.500 (38.10)	.410 (10.41)
BTMCTL-S-75-4.00-.50-**-	N/A	3/4" NPT	14.000 (355.60)	1.812 (46.02)	3.000 (76.20)	19.000 (482.60)	15.875 (403.23)	2-1/4 - 12 3.0 DP.	4.000 (101.60)	N/A	9.620 (244.35)	5.251 (133.38)	.500 (12.70)	1.750 (44.45)	17.068 (433.53)	49.731 (1263.17)	1.500 (38.10)	.410 (10.41)
BTMCTL-S-75-6.00-.50-**-	N/A	3/4" NPT	14.000 (355.60)	1.812 (46.02)	3.000 (76.20)	19.000 (482.60)	15.875 (403.23)	2-1/4 - 12 3.0 DP.	4.000 (101.60)	N/A	9.620 (244.35)	5.251 (133.38)	.500 (12.70)	1.750 (44.45)	21.068 (535.13)	52.470 (1332.74)	1.500 (38.10)	.410 (10.41)
BTMCTL-S-75-8.00-.50-**-	N/A	3/4" NPT	14.000 (355.60)	1.812 (46.02)	3.000 (76.20)	19.000 (482.60)	15.875 (403.23)	2-1/4 - 12 3.0 DP.	4.000 (101.60)	N/A	9.620 (244.35)	5.251 (133.38)	.500 (12.70)	1.750 (44.45)	25.068 (636.73)	55.208 (1402.28)	1.500 (38.10)	.410 (10.41)
BTMCTL-S-100-2.00-.25-**-	N/A	3/4" NPT	14.000 (355.60)	1.812 (46.02)	3.000 (76.20)	19.000 (482.60)	15.875 (403.23)	2-1/4 - 12 3.0 DP.	4.000 (101.60)	N/A	9.620 (244.35)	5.251 (133.38)	.500 (12.70)	1.750 (44.45)	13.068 (331.93)	41.046 (1042.57)	1.500 (38.10)	.410 (10.41)
BTMCTL-S-100-4.00-.50-**-	N/A	3/4" NPT	14.000 (355.60)	1.812 (46.02)	3.000 (76.20)	19.000 (482.60)	15.875 (403.23)	2-1/4 - 12 3.0 DP.	4.000 (101.60)	N/A	9.620 (244.35)	5.251 (133.38)	.500 (12.70)	1.750 (44.45)	17.068 (433.53)	56.255 (1428.88)	1.500 (38.10)	.410 (10.41)
BTMCTL-S-100-6.00-.50-**-	N/A	3/4" NPT	14.000 (355.60)	1.812 (46.02)	3.000 (76.20)	19.000 (482.60)	15.875 (403.23)	2-1/4 - 12 3.0 DP.	4.000 (101.60)	N/A	9.620 (244.35)	5.251 (133.38)	.500 (12.70)	1.750 (44.45)	21.068 (535.13)	58.963 (1497.66)	1.500 (38.10)	.410 (10.41)
BTMCTL-S-100-8.00-.50-**-	N/A	3/4" NPT	14.000 (355.60)	1.812 (46.02)	3.000 (76.20)	19.000 (482.60)	15.875 (403.23)	2-1/4 - 12 3.0 DP.	4.000 (101.60)	N/A	9.620 (244.35)	5.251 (133.38)	.500 (12.70)	1.750 (44.45)	25.068 (636.73)	61.671 (1566.44)	1.500 (38.10)	.410 (10.41)

Model numbers shown are standard cylinders. Other cylinder stroke lengths are available in .50" increments, power stroke lengths in .125" increments. Dimensions shown in inches with metric beneath (mm). **UH of FH mounting configuration is standard.

SATELLITE SERIES CYLINDERS ENGINEERING DATA

Air Pressure (PSI)	BTMCTL-S-1 Ton series	BTMCTL-S-2 Ton series	BTMCTL-S-4 Ton series	BTMCTL-S-8 Ton series	BTMCTL-S-10 Ton series	BTMCTL-S-15 Ton series	BTMCTL-S-20 Ton series	BTMCTL-S-30 Ton series	BTMCTL-S-50 Ton series	BTMCTL-S-75 Ton series	BTMCTL-S-100 Ton series
	Hyd PSI/Force lb.	Hyd PSI/Force lb.	Hyd PSI/Force lb.	Hyd PSI/Force lb.	Hyd PSI/Force lb.	Hyd PSI/Force lb.	Hyd PSI/Force lb.	Hyd PSI/Force lb.	Hyd PSI/Force lb.	Hyd PSI/Force lb.	Hyd PSI/Force lb.
30	210/670	330/16360	316/2626	379/4766	396/7785	480/9422	591/11601	651/19540	630/31663	592/46542	750/58905
40	280/893	440/2181	422/3501	506/6355	528/10380	644/12641	788/15468	921/26053	840/42218	790/62056	1000/78540
50	350/1117	550/2727	528/4377	632/7943	661/12975	805/15802	985/19335	1152/32567	1050/52773	987/77570	1250/98175
60	420/1340	660/3272	633/5252	758/9532	793/15570	966/18962	1182/23202	1382/39080	1260/63327	1185/93084	1500/117810
70	490/1563	770/3817	739/6127	885/11120	925/18165	1127/22123	1379/27069	1612/45593	1470/73882	1382/108598	1750/137445
80	560/1787	880/4363	844/7003	1011/12709	1057/20760	1288/25283	1576/30936	1843/52107	1680/84436	1580/124112	2000/157080
90	630/2010	990/4908	950/7878	1137/14298	1189/23355	1449/28443	1773/34803	2073/58620	1890/94991	1777/139626	2250/176715
100	700/2234	1100/5454	1056/8754	1264/15886	1322/25950	1600/31408	1970/38671	2304/65134	2100/105546	1975/155140	2500/196350

*Typical cylinder break-away pressure is 35 PSI.
 (1) Complete cylinder cycle @ 60 PSI.
 Multiply value by cycles per minute for total SCFM usage.

NOTE: The above specifications are theoretical forces. Frictional loads and lack of proper air supply may affect cylinder performance.
 Please multiply application force requirements by 1.25-1.50 to ensure adequate force is available.

	BTMCTL-S-1 Ton series	BTMCTL-S-2 Ton series	BTMCTL-S-4 Ton series	BTMCTL-S-8 Ton series	BTMCTL-S-10 Ton series	BTMCTL-S-15 Ton series	BTMCTL-S-20 Ton series	BTMCTL-S-30 Ton series	BTMCTL-S-50 Ton series	BTMCTL-S-75 Ton series	BTMCTL-S-100 Ton series
Approach Force per PSI (lbs.)	*3.14	*4.90	*8.29	*12.56	*19.63	*19.63	*19.63	*28.27	*50.26	*78.54	*78.54
Retract Force per PSI (lbs.)	*2.35	*4.11	*6.81	*11.08	*16.49	*16.49	*16.49	*23.37	*43.20	*65.97	*65.97
Output Force Range (lbs.)	670-2234	1636-5454	2626-8754	4766-15,886	7785-25,950	9424-31,408	11,635-38,785	19,540-65,134	31,663-105,546	46,542-155,140	58,905-196,350
Working Ratio (Output per PSI (lbs.))	22.34:1	54.54:1	87.62:1	158.86:1	259.62:1	314.08:1	387.85:1	651.44:1	1055.46:1	1551.40:1	1963.5:1
Service Ratio (Hydraulic PSI (lbs.))	7:01	11:1	10.56:1	12.64:1	13.22:1	16:1	19.7:1	23.04:1	21:1	19.8:1	25:1
Air Consumption per Cycle	.136 SCFM(1)	.267 SCFM(1)	.426 SCFM(1)	1.079 SCFM(1)	1.079 SCFM(1)	1.356 SCFM(1)	1.568 SCFM(1)	2.510 SCFM(1)	4.204 SCFM(1)	7.160 SCFM(1)	8.51 SCFM(1)
Operating Temperature	10°F-160°F	10°F-160°F	10°F-160°F	10°F-160°F	10°F-160°F	10°F-160°F	10°F-160°F	10°F-160°F	10°F-160°F	10°F-160°F	10°F-160°F
Maximum Operating Speed ***	1.5 Ft/sec	1.5 Ft/sec	1.5 Ft/sec	1.5 Ft/sec	1.5 Ft/sec	1.5 Ft/sec	1.5 Ft/sec	1.5 Ft/sec	1.5 Ft/sec	1.5 Ft/sec	1.5 Ft/sec
Recommended Air Filter	40 Micron	40 Micron	40 Micron	40 Micron	40 Micron	40 Micron	40 Micron	40 Micron	40 Micron	40 Micron	40 Micron
Maximum Operating Pressure	100 PSI	100 PSI	100 PSI	100 PSI	100 PSI	100 PSI	100 PSI	100 PSI	100 PSI	100 PSI	100 PSI
Minimum Operating Pressure	30 PSI	30 PSI	30 PSI	30 PSI	30 PSI	30 PSI	30 PSI	30 PSI	30 PSI	30 PSI	30 PSI

*Typical cylinder break-away pressure is 35 PSI.
 (1) Complete cylinder cycle @ 60 PSI.
 Multiply value by cycles per minute for total SCFM usage.
 *** Maximum speed of the seals (not maximum speed of cylinder).

NOTE: The above specifications are theoretical forces. Frictional loads and lack of proper air supply may affect cylinder performance.
 Please multiply application force requirements by 1.25-1.50 to ensure adequate force is available.

INTELLICYL® FOR QUALITY CONTROL

The IntelliCyl® is the successful combination of BTM Corporation's Air/Oil cylinder systems and state of the art electronic technology. IntelliCyl® was designed for applications where continuous monitoring of materials and processes is critical to the successful assembly of components.

IntelliCyl® consists of two options:

1. Low voltage Linear transducer (LVLT)
2. Fully integrated Load Cell installed on the end of the cylinder rod.

Both devices provide for an analog feedback signal through an analog card to the PLC. The feedback signals indicate distance (cylinder travel) to $\pm 0.001"$ and force (lbs.) applied to the tooling. The ability to monitor cylinder and tooling travel and force during the assembly process allows for:

Quality Improvement through in-process verification

- IntelliCyl®, HyperView-Press – verify dimensional stack-ups before you do work, and monitor the assembly process while you do work
- May eliminate costly EOL testing and destructive testing
- Drives quality into your assemblies. Drives out deviation
- Traceability – long-term data collection.

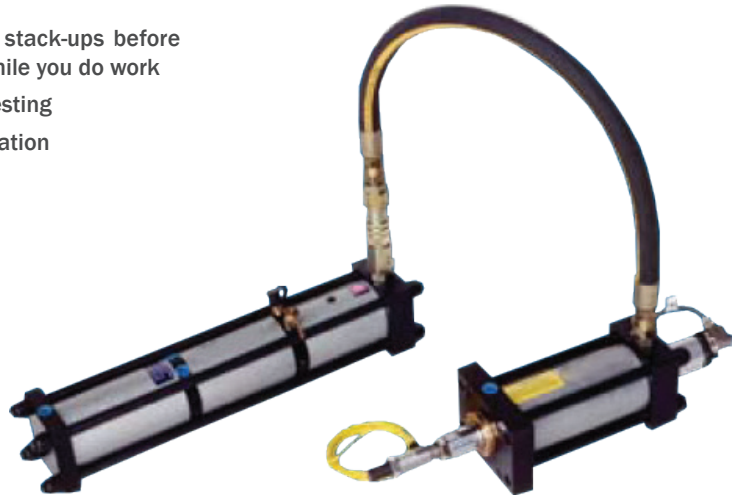

Standard Features

- Measure a part height (prior to assembly)
- Confirm multi-component stack-up dimension(s)
- Measure and confirm correct component(s) match-up
- Confirm end of stroke (extend/retract)
- Control distance travel during approach and power stroke cycles
- Monitor tool wear
- Monitor and confirm I.D./O.D. tolerance fit during assembly
- With known distance values, continuously monitored individual and multi-component finished part deviation from user set benchmarks or standards.
- HPS-LT option
- HPI-LTI option
- 3 year warranty

Output Force

11 size ranges from 1 - 100 tons (with specific model sizes), independent air regulation of extend/retract and power stroke forces and speeds.

Drive Unit

Hydra-pneumatic; Hybrid of pneumatic and hydraulic technologies utilize air to extend and retract the drive unit ram. Auto-sequencing into power stroke anywhere within the total cylinder travel, complete air/oil separation, operation in any attitude. Heavy-duty, continuous use (designed and built to exceed both NFPA and SAE guidelines) and compact design with a three-year warranty (please refer to Warranty Terms contained in catalog). Standard stroke lengths of 2.00", 4.00", 6.00" and 8.00" with power stroke lengths of .25", .50" and 1.00", (nonstandard stroke and power stroke lengths are available). Note: all drive units require (2) pneumatic air valves and minimum 40 micron pneumatic filter and regulator for operation.



Sensors

Distance – Low Voltage Linear Transducers - Magnetostrictive technology with Auto Tuning, non-contact, wear free, Analog, Digital, SSI, Pulse, CANopen, Profibus and Quadrature output, .0001" resolution capable, 7-pin connector/cable.

Resolution	≤0.66μA
Non-linearity	+/- 0.02% over full scale
Repeatability	Resolution/ min 2μm
Hysteresis	≤ 5μm
Sampling Rate	2KHz
Operating Voltage	24 Vdc or 15 Vdc

Force – Strain bridge design load cell. Load cell O.D. matches drive unit ram O.D. for a compact, integrated design. Mini Brad-Harrison style four 4-pin connector. Signal conditioner is required.

Rated Output	2mV/ V
Combined Error	0.25% of full scale
Non-repeatability	0.05%
Zero Balance	1%
Excitation Voltage	10VDC
Maximum Load	150% of full scale (safe) 200% of full scale (ultimate)

PSL Power Stroke Limiter

The “PSL” option limits the travel of the high pressure piston and rod assembly independent of the fast approach stroke of the cylinder. Precise control (± 0.004) of the high pressure stroke is desirable for applications such as marking and part assembly.



TSL Total Stroke Limiter

The “TSL” option limits the total stroke of the cylinder, including the power stroke. Adjustment is accomplished by rotating the adjustment barrel and locking ring. *Not available on HPI units.*



PB Pressure Block

The “PB” Pressure Block can be used to remotely monitor/control the hydraulic oil pressure of all BTM Air/Oil cylinders.

Includes gage. IC-1 coupling must be ordered separately.



IC-1 Pressure Coupling

Standard on all cylinders, the IC-1 coupling is required to connect a “PHA” hose assembly to the “PB” pressure block.



GA-1 Gage Adapter Coupling

The GA-1 adapter coupling is required when installing a customer supplied hydraulic gage (1/4” NPT).



High Pressure Hose Assemblies

PHA hose assemblies connect the cylinder to a PB Pressure Block. Available in various lengths.

Working Pressure	0 - 6000 PSI	
	PHA-12”	PHA-24”
	PHA-36”	PHA-48”
	PHA-60”	PHA-72”



Hydraulic Gage Kits

Hydraulic gage kits allow monitoring of the internal hydraulic oil pressure. Kits include a gage, GA-1 coupling and T-fitting. All cylinder series: G-01 (0-3000 PSI liquid filled)



All options can be installed at the factory. If options are customer installed, refilling and venting of the reservoir may be necessary before cylinder operation.



CAUTION! - Always disconnect air and electrical supply lines before working on or around Air/Oil Cylinders!

HFP-1, HFP- 2 Hyperfill Units

HyperFill refilling units are self-contained devices used to replenish oil in the reservoir section of all BTM Air/Oil cylinders. The HFP-1 includes the fill unit, fill coupling, 3' hose assembly and complete instructions. Refilling is a simple 3-step process. The HFP-2 unit is manually operated.



PT/ELT sensors

PT/ELT series sensors provide a pneumatic (PT) or electrical (ELT) output signal when the cylinder work rod and tooling have contacted the work surface. Typically used to sequence BTM Air/Oil cylinders into high pressure. Sensor installs into the "B1" port.

Model Series	Size	Part Number (PT or ELT)
BTMCYL-I/S-1	1/8" NPT	PT/ELT1
BTMCYL-I/S-2	1/4" NPT	PT/ELT-2
BTMCYL-I/S-4, 8	3/8" NPT	PT/ELT-3
BTMCYL-I/S-10, 15, 20	1/2" NPT	PT/ELT-4
BTMCYL-I/S-30	3/4" NPT	PT/ELT-5

Rod Lock Option

The "AL" Rod Lock option is a locking device installed on the head end of the cylinder that provides a positive locking of the cylinder rod when air is removed from the lock. The locking action is designed where safety considerations require positive locking of the tooling/actuator when air pressure is removed from the circuit. The rod lock option is available for all 1 through 30 ton BTM Air/Oil cylinders. Rod Lock - 60 PSI minimum air pressure required.

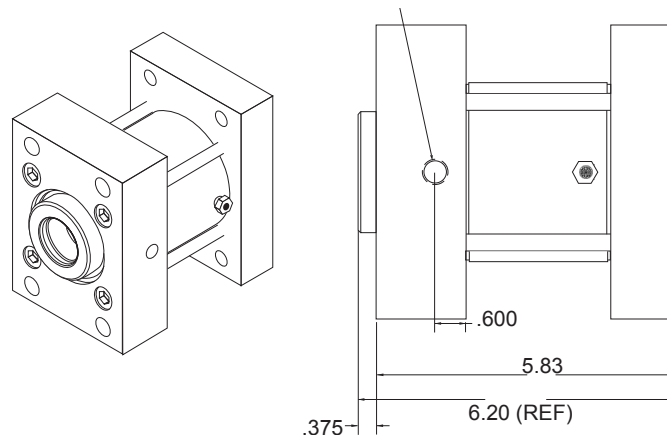

Die Set Couplings

The PAF/Q Series alignment coupling is a flexible, quick-change connection for use with all BTM Air/Oil cylinders and conventional die sets. The coupling provides an axial float between the cylinder and customer supplied die set, minimizing side loading of the cylinder rod, extending cylinder life. Alloy steel (Rockwell "C" 58/60) construction with black oxide finish. All coupling sets include 1 cylinder coupling, 1 PAF or PAQ die flange, and socket head cap screws.

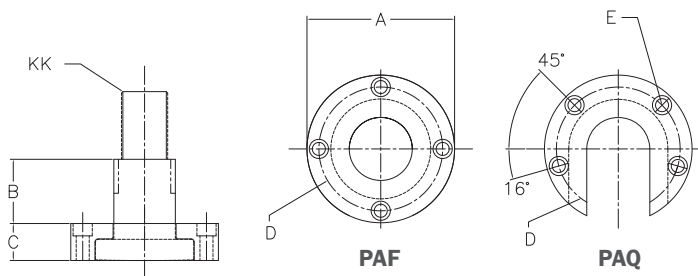

Cylinder	Model No.	A	B	C	D	E	KK
BTMCYL-I/S-1, 2	PAF-1, PAQ-1	3.250	1.000	.875	2.610	1/4-20 x 1.50 SHCS	3/4-16 x 1.00"
BTMCYL-I/S-4, 8	PAF-4, PAQ-4	3.500	1.500	1.125	2.930	5/16-18 x 2.00 SHCS	3/4-16 x 1.00"
BTMCYL-I/S-10, 15, 20	PAF-10, PAQ-10	5.000	2.000	1.500	4.280	3/8-16 x 2.00 SHCS	1 1/2-12 x 2.00"
BTMCYL-I-30	PAF-30, PAQ-30	6.000	2.750	1.500	5.030	1/2-13 x 2.00 SHCS	1 7/8-12 x 2.75"
BTMCYL-I-50	PAF-50, PAQ-50	6.000	2.750	1.500	5.030	1/2-13 x 2.00 SHCS	2 1/4-12 x 2.75"

All options can be installed at the factory. If options are customer installed, refilling and venting of the reservoir may be necessary before cylinder operation.

Hydraulic pressure switches are used to confirm the internal hydraulic pressure during the power stroke of the cylinder. Pressure switches are user adjustable and provide a contact closure (output signal) to confirm cycle complete.

SW Pressure Switch

SW series switches provide a dry contact, manually adjusted set point way to monitor the internal hydraulic pressure of all BTM Air/Oil cylinders during the power stroke. Once pressure has been achieved (confirming cylinder force) contact closure output can be utilized to retract the cylinder.

SW-01 (suitable for all series cylinders except 100 ton)

- Adjustable range from 150-2300 PSI
- Repeatability of 3%
- Maximum switching rate of 100 CPM
- Electrical protection NEMA 4
- Electrical rating AC/DC 5A
- Electrical connection: 3-Pin (DIN) connector, included



SWD Pressure Switch

SWD series digital pressure switches provide a four-digit display in the programming of the switch points and an accurate readout of cylinder pressure and set points. SWD series switches also provide a 4-20ma output signal which may be used for data collection, remote display or alarm functions.

SWD-01 (0-1450 PSI, 20-30 VDC, PNP or NPN Output)

SWD-02 (15-3625 PSI, 20-30 VDC, PNP or NPN Output)

- Repeatability $\pm 0.25\%$ of range
- Switching frequency is adjustable
- Switch point accuracy of $\pm 2\%$ of full range
- Electrical connection: 4-Pin Micro DC



Note: Please contact BTM for appropriate cable set.

CONTROL CIRCUITS



CAUTION! - Always disconnect air and electrical supply lines before working on or around Air/Oil Cylinders!

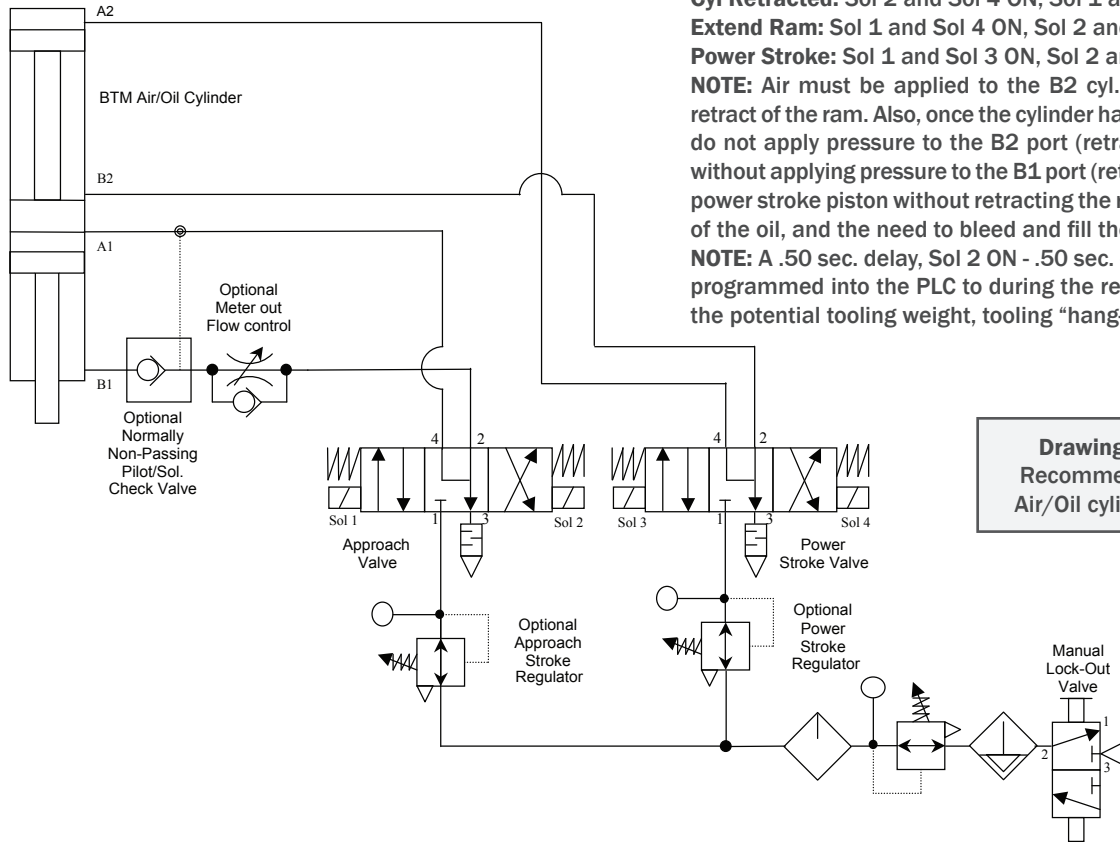

Cyl Retracted: Sol 2 and Sol 4 ON, Sol 1 and Sol 3 OFF
Extend Ram: Sol 1 and Sol 4 ON, Sol 2 and Sol 3 OFF
Power Stroke: Sol 1 and Sol 3 ON, Sol 2 and Sol 4 OFF
NOTE: Air must be applied to the B2 cyl. port during extend and retract of the ram. Also, once the cylinder has gone into power stroke, do not apply pressure to the B2 port (retract power stroke piston) without applying pressure to the B1 port (retract ram). Retracting the power stroke piston without retracting the ram can cause cavitation of the oil, and the need to bleed and fill the unit.
NOTE: A .50 sec. delay, Sol 2 ON - .50 sec. delay - Sol 4 ON may be programmed into the PLC to during the retract stroke to eliminate the potential tooling weight, tooling "hang-up" cavitation.

Drawing #02-3POS-CK
 Recommended for all BTM Air/Oil cylinder installations

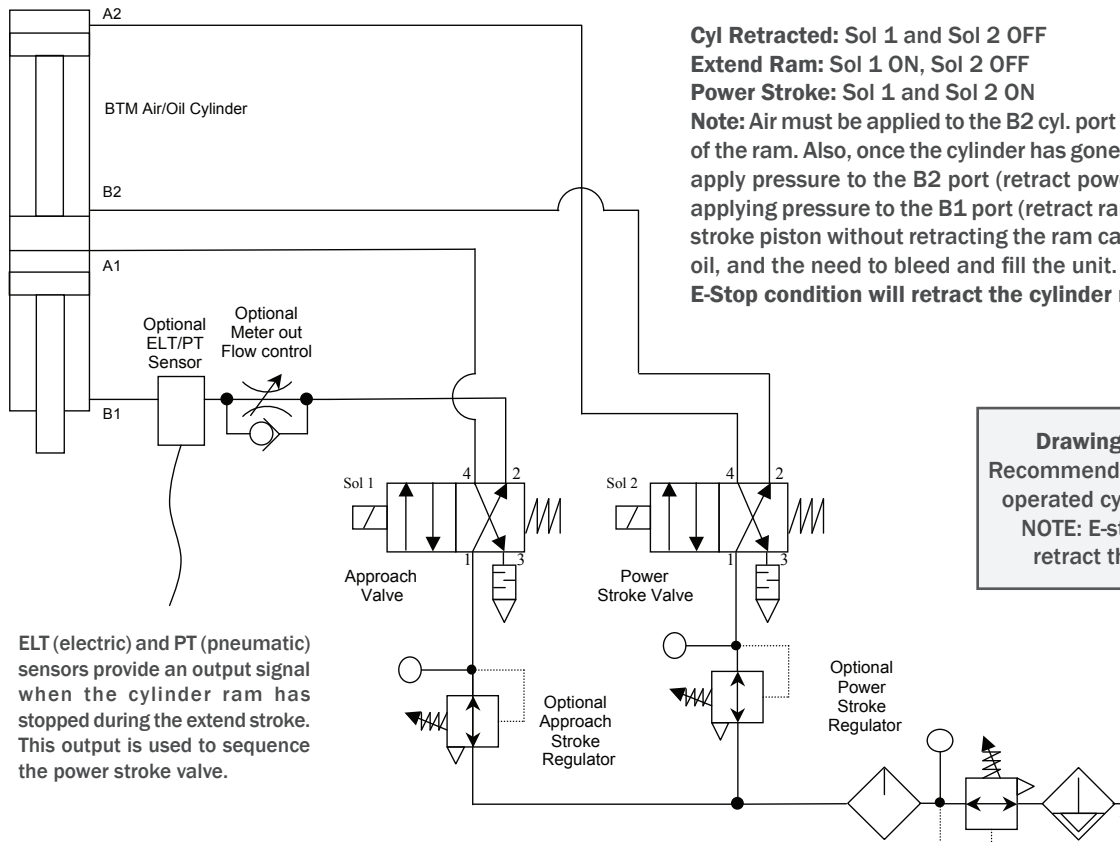

Cyl Retracted: Sol 1 and Sol 2 OFF
Extend Ram: Sol 1 ON, Sol 2 OFF
Power Stroke: Sol 1 and Sol 2 ON
Note: Air must be applied to the B2 cyl. port during extend and retract of the ram. Also, once the cylinder has gone into power stroke, do not apply pressure to the B2 port (retract power stroke piston) without applying pressure to the B1 port (retract ram). Retracting the power stroke piston without retracting the ram can cause cavitation of the oil, and the need to bleed and fill the unit.
E-Stop condition will retract the cylinder ram

Drawing #02-2POS-ELT
 Recommended for non-manually operated cylinder installations
NOTE: E-stop condition will retract the cylinder ram.

ELT (electric) and PT (pneumatic) sensors provide an output signal when the cylinder ram has stopped during the extend stroke. This output is used to sequence the power stroke valve.



CAUTION! - Always disconnect air and electrical supply lines before working on or around Air/Oil Cylinders!

WARNING! - All BTM Air/Oil cylinders are capable of providing high forces with little or no noise. Please use caution. Use of adequate external safeguarding is **mandatory**.

- Attach the cylinder to the mounting surface using Grade 8 bolts of the largest diameter possible, with a lock washer or locking type material. (Locktite)
- Provide a way to reduce or eliminate side loading the cylinder rod. Failure to do so will cause excessive wear on the guide bearings, seals and wear strips. Cylinders returned for repair in this condition will not be covered under warranty.
- All cylinders are provided with a high pressure (hydraulic-gage port) coupling, and fill coupling as standard. Allow room to access for future options and service.
- Punching and piercing applications must provide an external resistance to the rod and tooling prior to breaking through (refer to drawing below). Failure to do so can cause a vacuum inside the cylinder, adversely affecting performance.
- For best cylinder performance, air directional control valves should be mounted within five (5) feet of the cylinder.
- Use of nylon or equivalent tubing is recommended for all connections from the air directional control valves to the cylinder. Tubing diameter should be at least equal to the cylinder port size, i.e. 3/8" N.P.T. cylinder ports – 3/8" diameter tubing.
- For safety, install a lockout valve prior to the F.R.L. unit.
- A 40 micron filtration system is recommended. Air line lubrication is at the customer's option. However, be advised that air lubrication will extend cylinder life approx. 20%.
- Pneumatic flow control valves can be installed (meter out) at any port to control the respective cycle speed. Port "B1" to control cylinder advance, port "A1" to control cylinder retract speeds.
- Do not exceed 100 PSI air pressure to the cylinder.
- If required, fully extending the cylinder before sequencing into high pressure is acceptable.
- If the air supply is to be shut off for an extended period of time and tooling weight exceeds 25% of the cylinder approach force, mechanically block tooling in the retracted position.

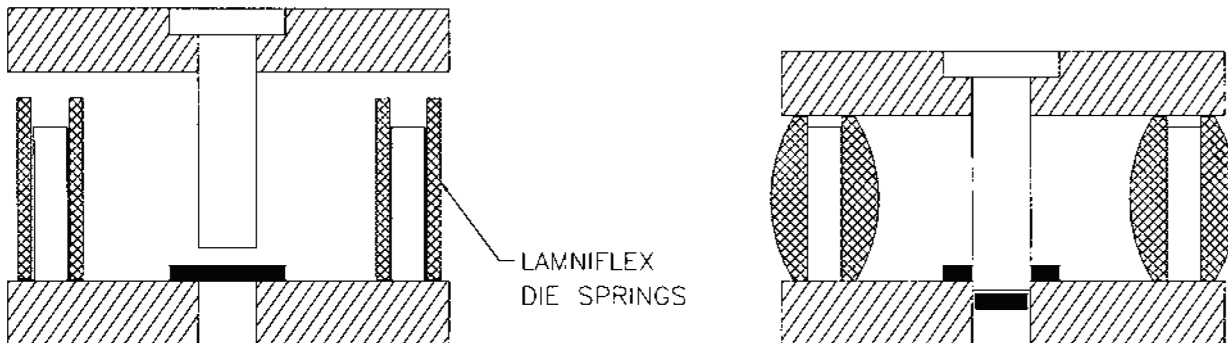

In many applications, the forward travel of the cylinder during high pressure is limited by the application itself, such as resistance welding, staking, etc. However, for punching and piercing applications the forward travel of the cylinder must be limited after punching through the material. If external resistance is not provided, the cylinder rod will continue to travel causing a potential vacuum in the high pressure reservoir sections of the cylinder, adversely affecting performance. If a single point punch is used on the application, a single spring may be located around the punch, which will also act as a stripper spring. We recommend use of LamniFlex Polyurethane Die Springs. Please contact BTM for additional information.

HOW TO ORDER

Options such as sensors, HyperFill Units and switches must be ordered separately. refer to pages 18-19.

IN-LINE SERIES ORDERING INFORMATION

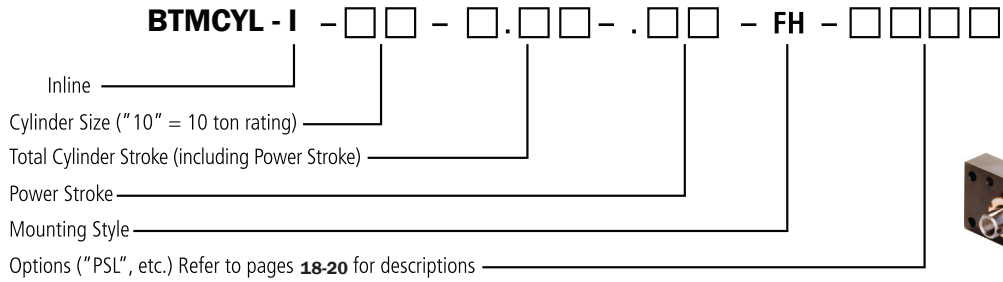

SATELLITE SERIES ORDERING INFORMATION

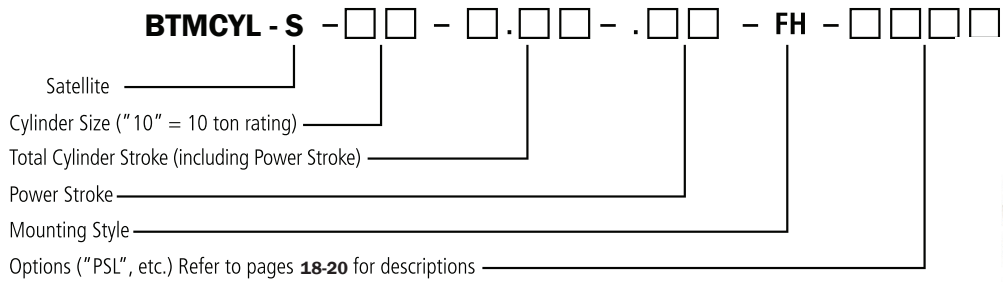

BTM has a wide range of products to meet your needs including (but definitely not limited to):

PNEUMATIC CLAMPS & GRIPPERS

Light & Heavy Duty Clamps

Clamps range from light duty omni-directional head clamps to heavy duty precision sealed power clamps.

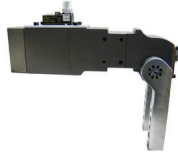

Light & Heavy Duty Grippers

BTM's Gripper line ranges from compact light duty models to locking & non-locking heavy duty models.



SHEET METAL JOINING

Tog-L-Loc[®]

BTM's Tog-L-Loc[®] sheet metal joining system is a cold forming process that quickly joins pre-painted, galvanized, coated, and dissimilar metals.



Lance-N-Loc[®]

BTM's Lance-N-Loc[®] Joining System produces clean, strong and consistent joints in most coated or uncoated metals.



PIN PRODUCTS

Precision Shot Pin cylinders

BTM's Precision Part Locators are used whenever your production needs require locating precise holes in a workpiece.

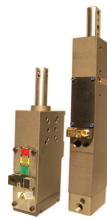

Pin Locator Clamps

BTMs' Pin Locator Clamps and Single Finger clamps are used in stationary part nests, welding fixtures, transfer systems, robot end effectors and numerous other clamping applications. These clamps locate and hold the work while other operations are performed.



Standard pin sizes range from 12.5mm - 40mm.

Ways to Tog-L-Loc[®]



Die Sets



Handheld Units



Hydraulic Units



Universal Presses



Specialized Units

For more information, or to see our full line of products, please visit:

WWW.BTMCOMP.COM