

TPC-32 Compact Power Clamp

Weld-Contamination Sealed, Pneumatic, Precision, Locking Power Clamp

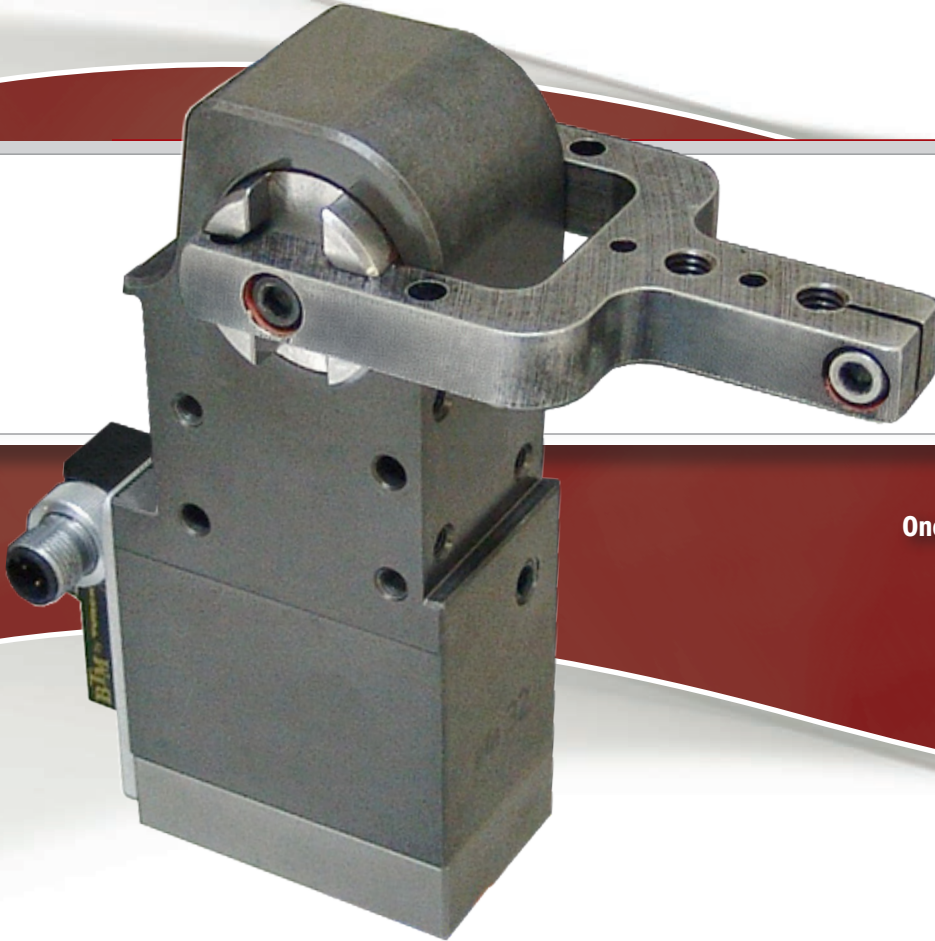

One Clamp Model for Single & Dual Arm Clamps

Uses a TRILOCK Locking Mechanism

Compact & Light-Weight

BTM[®]

**SAFETY NOTE**

It is the customer and/or user's responsibility to provide proper safety controls and/or guarding when a pinch point is present.

INTRODUCTION

BTM TPC-32 features a 32mm bore, and a three point locking mechanism which is designed to remain locked even if air pressure is lost. This clamp is compact, light-weight, and sealed against weld-contamination.

TPC-32 CLAMP FEATURES

- TriLok Mechanism
- Sealed Mechanism - Lubricated for Life of Clamp
- Integral Cylinder with Heavy Wall
- Body is Constructed of Aircraft Aluminum, Hard Coated to a Rockwell C-70 for Excellent Wear Characteristics
- One Clamp Model for Single and Dual Arm Clamps
- Access to Manually Unlock Clamp Linkage
- Integrated Proximity Switches do not need to be Readjusted when Arm Opening Changes.

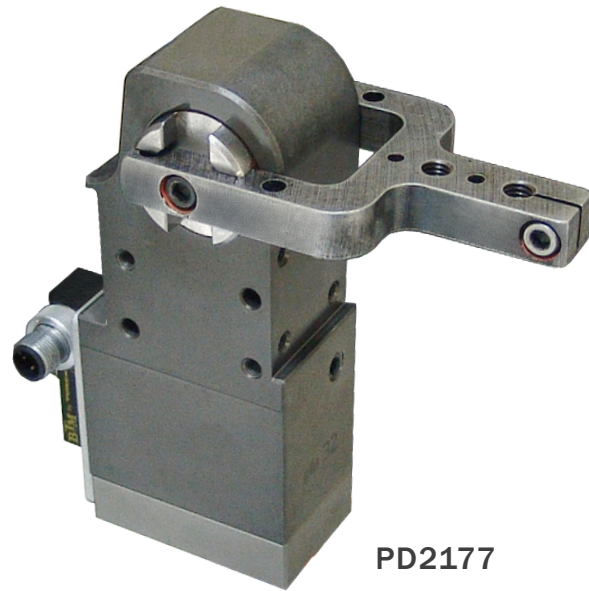
**PD2177****TABLE OF CONTENTS**

TPC-32	2-5
Switch Information	6
Warranty Information	7
Global Operations Sales Support Teams	Back Cover

BTM reserves the right to make changes to its literature without any prior notice. Visit btmcomp.com for latest version.
©2026 BTM Company, L.L.C. All related logos, product names, icons, designs, products, and services shown herein are among the trademarks owned by BTM Company, L.L.C. Copyrights and trademarks of BTM Company, L.L.C., BTM Europe, BTM Scandinavia AB, or other affiliates are the property of their respective owners. All rights are reserved.

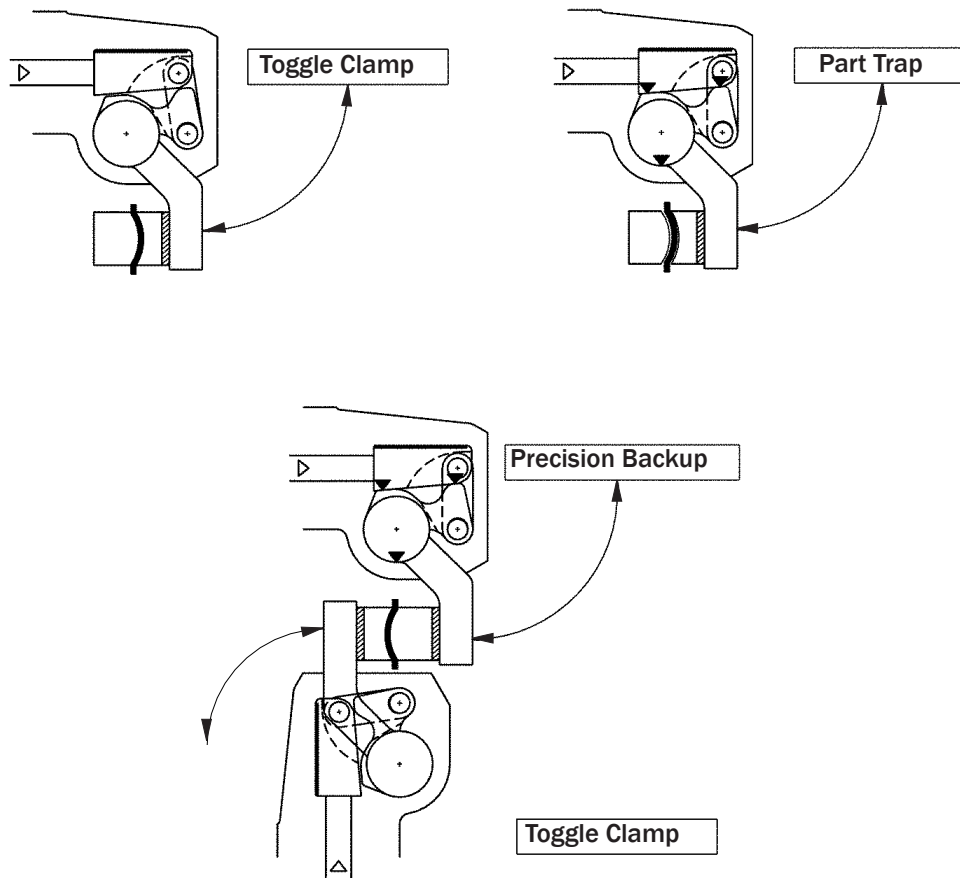
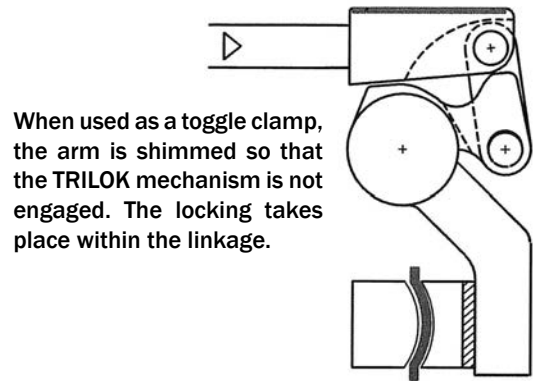
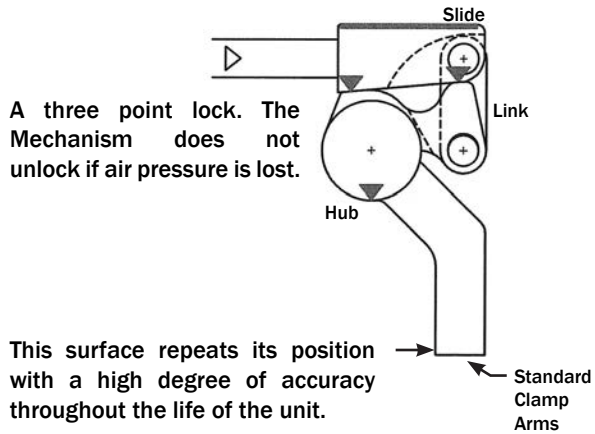
TPC-32 CLAMPS UTILIZE **TRILOK TECHNOLOGY**

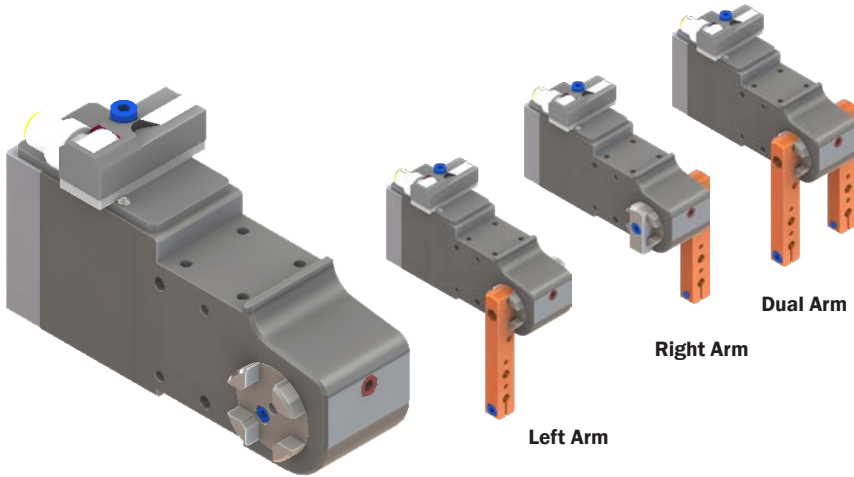

Bore Size	31.8 [1.25] DIA. - 791.7mm ² [1.23in ²]						
Arm Rotation (Deg.)	35	50	65	80	95	110	120
Cylinder Stroke (mm)	11.5	14.1	16.6	19.2	21.8	24.4	24.6
Maximum Full Cycle Cylinder Volume	38.5 cm ³ [2.35in ³]						
Recommended Operating Pressure	2.75 to 7 BAR [40 to 100 PSI] (Lubricated or Non-Lubricated Compressed Air)						
Weight	1.0 kg [2.21 lbs] Without Arm						
Clamping Torque	12.4 Nm @ 5.5 BAR [9.16 lbf @ 80 PSI]						
Cycle Time (based on a 120° opening at 5.5 BAR [80PSI])	1.0 second closing cycle 1.25 second opening cycle						

CLAMPING FORCE	
BARS	2253 x Line Pressure (BAR)
	Length (mm) from POINT "A" to the center line of clamping contact area on clamp arm
PSI	1.375 x Line Pressure (PSI)
	Length (in) from POINT "A" to the center line of clamping contact area on clamp arm

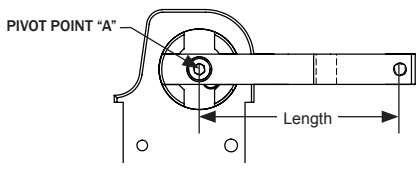

PORT OPTION	
N	1/8 NPT
G	G1/8
CLAMP ASSEMBLY	
Arm Opening	BTM Number
35°	PD217700A
50°	PD217700B
65°	PD217700C
80°	PD217700D
95°	PD217700E
110°	PD217700F
120°	PD217700G

ARM STYLE

SEE PG. 5

ARM POSITION

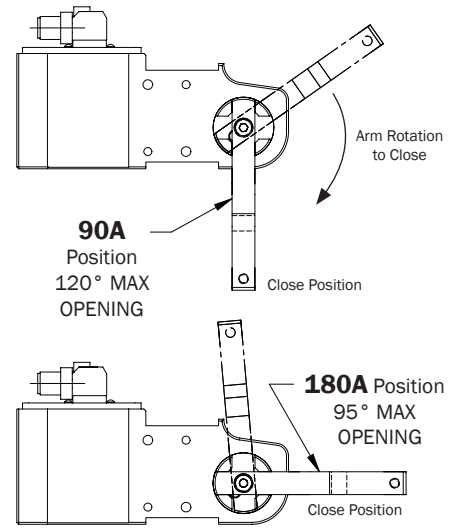

SWITCH - (SEE PG. 6 FOR MORE INFO)

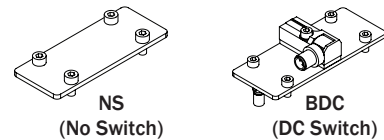

HOW TO ORDER

CLAMP				LEFT ARM			RIGHT ARM			OFFSET ARM MOUNTING	SWITCH
TPC	32	N	120	783502H	90A	L	783502H	90A	R	OAM	BDC
CLAMP SERIES	CLAMP SIZE	PORT OPTION	ARM OPENING	ARM STYLE	ARM POSITION	ARM SIDE	ARM STYLE	ARM POSITION	ARM SIDE	OFFSET ARM MOUNT (leave blank for normal mounting)	SWITCH CODE

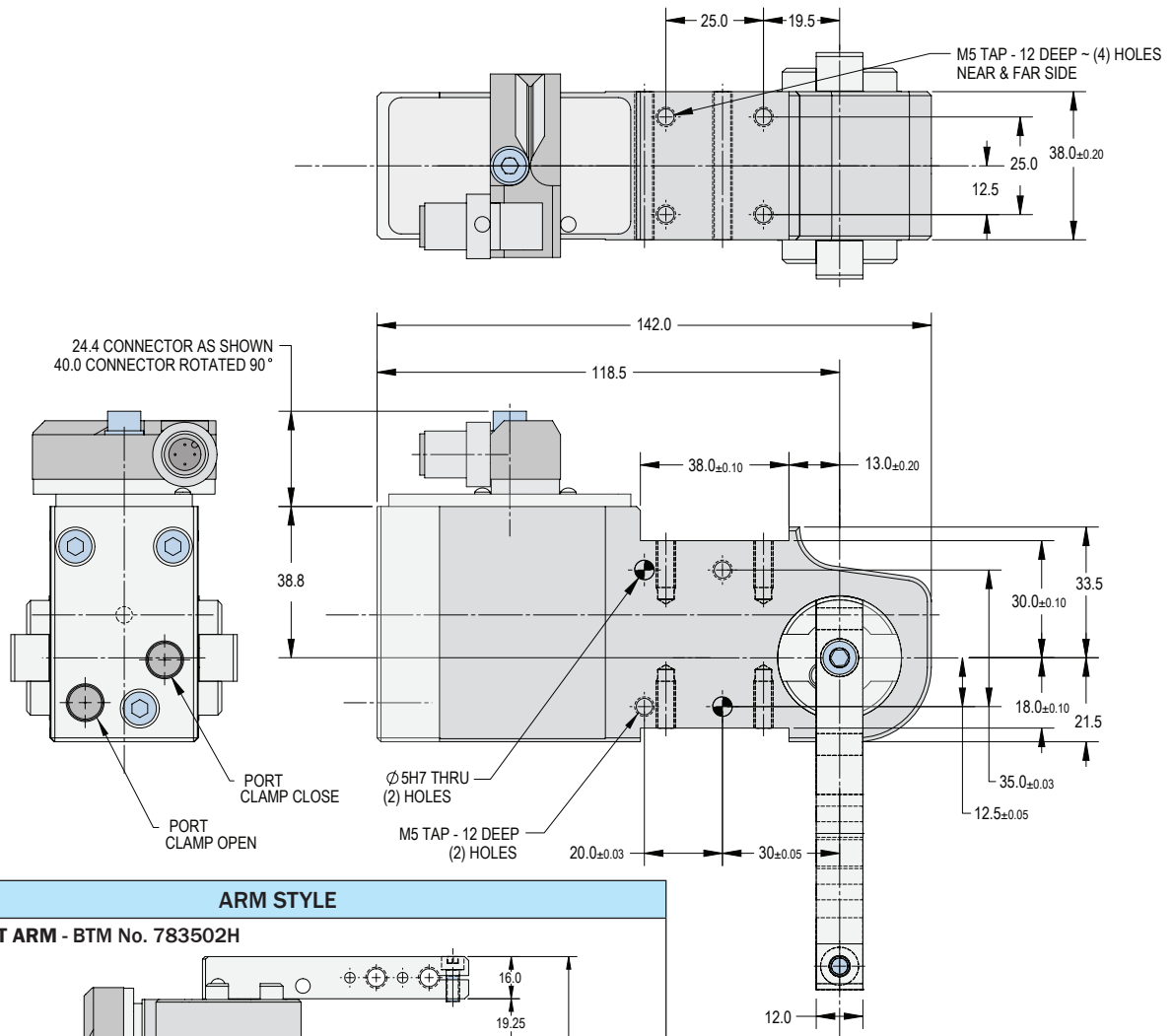

ARM STYLE

STRAIGHT ARM - BTM No. 783502H

16.0
19.25
27.25
70.5

Note: Please see "Yoke Arm" Below for dimensions not shown.

YOKE ARM - BTM No. 783501H

78.8 MAX.
85.0
50.0±0.13
Ø4 H7 THRU (2) HOLES
M8 TAP THRU (2) HOLES
16.0
20.0±0.13
40.0±0.13
20.0±0.02
58.0
47.0

OFFSET ARM MOUNTING (OAM) OPTION

OAM OPTION - BTM No. 783503H

OFFSET ARM MOUNT ORDER CODE "OAM" MOUNTS RIGHT, LEFT, OR DUAL 90A POSITION SHOWN

MAX. WEIGHT ALLOWABLE ON CLAMP ARM

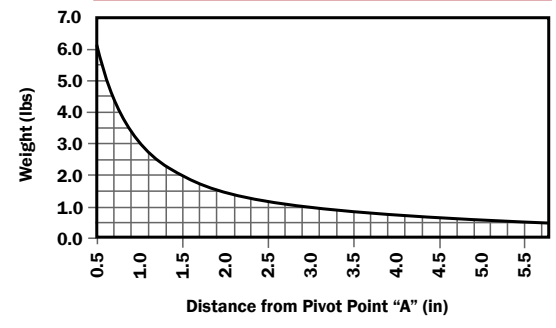
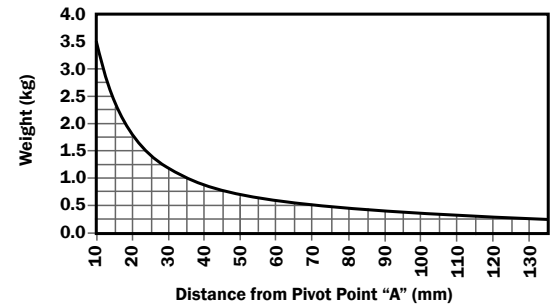

BDC - TURCK DC

Ni2-BTM-0,16-BDS-2AP6X3-H1141/S34

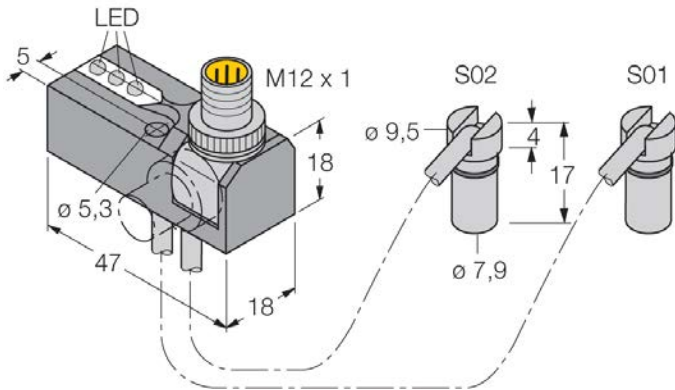

LED INDICATORS

YELLOW - S01 OUTPUT ENERGIZED
 GREEN - POWER ON
 RED - S02 OUTPUT ENERGIZED

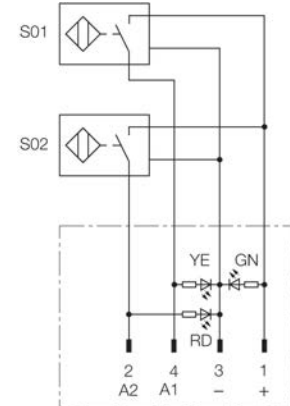

SPECIFICATIONS

RATED OPERATING DISTANCE S_n	2mm
MOUNTING MODE	NON-FLUSH
HYSTERESIS H (DIFFERENTIAL TRAVEL)	3 - 15%
MAX. RELATIVE TEMPERATURE DRIFT	$\leq \pm 10\%$
MIN. REPEAT ACCURACY	$\leq 2\%$
OPERATION TEMPERATURE	-25°C to +70°C (-13°F to +158°F)
RATED OPERATIONAL VOLTAGE (DC) U_b	10-30 VDC
MAX. RIPPLE	$\leq 10\% U_{ss}$
RATED OPERATIONAL CURRENT (DC) I_b	≤ 200 mA
NO-LOAD CURRENT I_0	≤ 15 mA
MAX. OFF-STATE CURRENT	$\leq 0,1$ mA
MAX. SWITCHING FREQUENCY	$\leq 0,03$ kHz
RATED INSULATION VOLTAGE	0,5 kV
OUTPUT FUNCTION	4-WIRE, NORMALLY OPEN, PNP
SHORT-CIRCUIT PROTECTION	YES
MAX. VOLTAGE DROP AT I_b	$\leq 1,8$ V
WIRE BREAKAGE AND REVERSE POLARITY PROTECTION	YES, COMPLETE
DEGREE OF PROTECTION	IP 67
HOUSING STYLE	DUAL SENSOR; BTM
DIMENSIONS	47 X 18 X 18mm (1.85" X .71" X .71")
HOUSING MATERIAL	PLASTIC, PBT-GF20-V0
WIRING	CONNECTOR, M12X1 EUROCON
CABLE	$\varnothing 2$; LiF9Y-11Y3; PUR; 0,16 m
CROSS SECTION	3 X 0,08mm ²
VIBRATION RESISTANCE	55 Hz (1 mm)
SHOCK RESISTANCE	30 X g (11 ms)

WARRANTY INFORMATION

BTM Company, LLC. warrants its TPC-32 Power Clamps against defects in material and workmanship for a period of one (1) year after ship date from BTM.

This warranty is limited to replacing or repairing at the option of BTM, F.O.B. BTM factory, any part found by BTM to be defective in materials and/or workmanship. Any application of a BTM product outside the intended use of the product shall not be warranted by BTM Company, LLC. Furthermore, BTM will not be liable for any expenses incurred for repairs or replacement made outside BTM facilities without written consent (or damages arising out of such replacements or repairs). Under no circumstances will BTM be held responsible for any consequential damages.

The warranty is limited to the repair or replacement of the defective part(s) and does not include installation.

This warranty is the only warranty extended by the seller in connection with any sale made hereunder and is in lieu of all other warranties, express, implied or statutory including warranties of merchantability and fitness for purpose.

BTM WORK HOLDING QUALITY PRODUCTS

Clamps



From heavy duty precision sealed locking power clamps to simple light duty OMNI models, BTM manufactures clamps in a range of styles and sizes for a wide variety of applications.

Grippers



BTM manufactures a high quality line of grippers ranging from heavy duty models to light duty models in a variety of styles and sizes.

Pin Locator Clamps



BTM Locator Clamps are ideal for locating & holding production material and are used in a variety of manufacturing areas including automotive & refrigeration.

Pin sizes range from as small as 6mm (PLC-25 Light Duty Clamp) to as large as 40mm (PLC-63 & LPLC-38 locking clamp).

Single Finger Hook Models (without the locating pin) are also available in both locking and non-locking configurations.

Rod-Locking Pin Locator Clamps



These clamps employ a rod locking feature which allows the clamp to retain the part when air pressure is removed/lost.

Precision Part Locators



BTM Precision Part Locators are ideal for locating production material through precisely pierced holes - including clamping and fixturing.

CONTACT YOUR LOCAL BTM SALES TEAM FOR SUPPORT

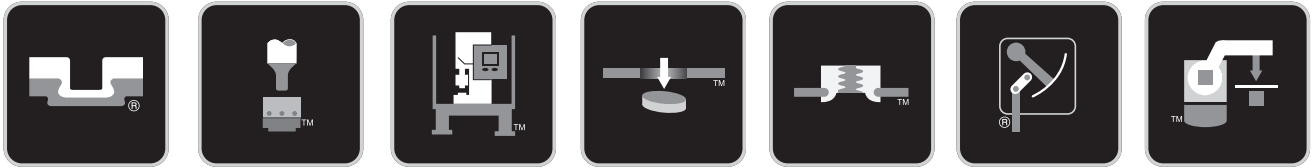

Clinching | Clinch Tooling | Clenching, Piercing & Fastener Equipment | Presses & Press Units | Work Holding

LOCAL Customer Relationships & Project Support		
LOCAL Application Expertise Supported By Globally Shared Expertise	LOCAL Engineering & Manufacturing For Project Specific Content	LOCAL After-Sales Support Leveraged For Global Coverage
GLOBAL Shared Research & Technology Development		
GLOBAL Manufacturing For Scale Optimized Content		



BTM[®]
COMPANY
USA | CANADA
Global Headquarters
btmcomp.com
sales@btmcomp.com
+1.810.364.4567

BTM[®]
EUROPE
btm-europe.de
info@btm-europe.de
Head Office: +49 2943 9790-0
Branch Office: +49 7841 68136-0

BTM[®]
KOREA
btmkorea.com
betem@btmkorea.com
+82 31 477 4202

BTM[®]
MEXICO
btmcomp.com
salesmx@btmcomp.com
+52 442 341 5601

BTM[®]
SCANDINAVIA
btmscand.se
btm@btmscand.se
+46 480-868 75

BTM[®]
SOUTH AMERICA
gptech.ind.br
contato@gptech.ind.br
+5547 3425 8716

BTM[®]
UNITED KINGDOM
btm-europe.de
info@btm-europe.de
+49 2943 9790-0

HR Hawker
Richardson
AUSTRALASIA
hawkerrichardson.com.au
web@hrltd.com.au
+61 1300 36 00 31

dkPOWER[®]
TURKEY
dkpower.com
dk@dk-power.com
+90 224 482 40 40

HERON[®]
CHINA
heronwelder.com
bill@heronwelder.com
+86 136 02866179

TECNOPRESS[®]
MEXICO
technopress.com.mx
+52 55 53632758

FOR REST OF WORLD, CONTACT BTM COMPANY